

LÄMPÖÄSSÄ
Vsi 6 – 14

100%
GEOHERMAL HEAT

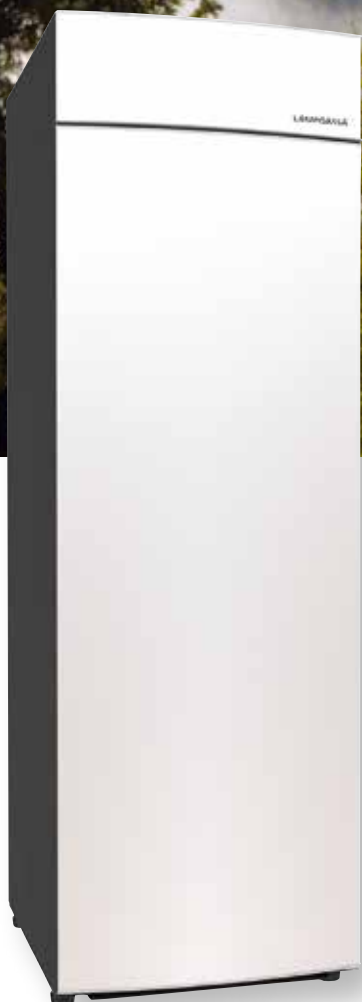

**INSTRUCTIONS FOR USE,
INSTALLATION AND MAINTENANCE**

100% GEOTHERMAL HEAT

Foreword

We thank you for your confidence in our products and congratulate you on making an excellent choice! You have selected a long-lasting and environmentally friendly Lämpöässä geothermal heat system. We hope that you will enjoy the trouble-free heating provided by Lämpöässä for many decades to come. Please familiarize yourself with these instructions for use and maintenance. Keep the instructions for future use and reference should problems occur.

These instructions consist of three manuals drawn up with consideration of different user groups. The instructions for use include manuals intended for users, installers, and maintenance personnel. The instructions also separately contain warranty conditions, technical specifications, and connection diagrams.

CONTENTS

USER MANUAL

1. Safety	4
2. Geothermal heating system operation	4
2.1 Lämpöässä Vsi series structure and operating principle	5
2.1.1. Heat collection circuit	5
2.1.2. Compressor unit	5
2.1.3. Hot water storage tank	5
2.2 ÄssäCooling cooling system	6
3. How to use the equipment	6
3.1. Control system functioning	6
3.2. Touch screen functioning	7
3.3. Setting the time and date	7
3.4 Function shortcuts	7
3.4.1. Room temperature adjustment	7
3.4.2. Room temperature adjustment by room temperature measurement (optional equipment)	7
3.4.3. Domestic water boost	8
3.4.4. Home/Away function	8
3.4.5. Measurements	9
3.4.6. Timer functions	9
3.4.7. Adjustment curves	10
3.4.8. Storage tank settings	10
3.4.9. Optional equipment	10
3.5. Menu functions	10
3.5.1. Storage tank settings	10
3.5.2. Adjustment curves	11
3.5.3. Other set values	12
3.5.4. Measurements	14
3.5.5. Optional equipment	14

INSTALLER MANUAL

4. INSTALLATION WORKS	15
4.1. Before installation	15
4.1.1. Transport	15
4.1.2. Ground source heat pump installation area	15
4.1.3. Removing the packaging	15
4.1.4. Space requirements	15
4.2. HVAC installation	16
4.2.1. Heat collection circuit and fill group installation	16
4.2.2. Filling and de-aeration of the heat collection circuit	16
4.2.3. Heating and domestic hot water connections	17
4.2.4. HVAC checklist	18
4.3. Electrical installation and outdoor sensors	19
4.3.1. Outdoor sensor	19
4.3.2. Room sensor (optional)	19
4.3.3. Current monitor	19
4.3.4. Electrician's checklist	20
4.4. Commissioning	20

MAINTENANCE MANUAL

5. MAINTENANCE	22
5.1. Maintenance and care	22
5.2. Possible problems occurring during use	22
5.3. Alarms	23
5.4. Maintenance procedures	23
5.4.1. Manual control	23
5.4.2. Input and output statuses	24
5.4.3. Running information	25
5.4.4. Heat distribution circuit quantity	25
5.4.5. Domestic hot water temperature limit	25
5.4.6. Positioning valve control	26
5.4.7. Part-power / Full power	27
5.4.8. Resistor controlling method	27
5.4.9. Temperature gauges	27
5.4.10. External alarm	27
5.4.11. Soft starter alarms	27
5.4.12. Super heat valve control	28
5.4.13. Boiler maximum limits	28
5.4.14. Factory settings	28

6. WARRANTY CONDITIONS	29
7. TECHNICAL SPECIFICATIONS	30
8. ENERGY LABEL	32
9. ELECTRICITY SCHEMES	60
10. HVAC SCHEMES	83

100% GEOTHERMAL HEAT

USER MANUAL

1. Safety

In order to ensure trouble-free operation of the Lämpöässä geothermal heating system and achieve the best efficiency, the system must be transported and installed in accordance with the manufacturer's instructions. After performance of installation works, the installation checklist must be reviewed in order to minimise the risk of potential errors. The manufacturer shall not accept any responsibility for equipment defects or related expenses caused through installation faults.

The pipe and electrical installations for the Lämpöässä geothermal heating systems can only be installed by qualified persons. If problems should occur during installation, we recommend that you contact your dealer or consult with Lämpöässä maintenance specialists by phone.



If the fault symbol is displayed on the touch screen, a system malfunction has occurred. Press this button to display information on the cause of the malfunction.



Press this button for additional information on the touch screen data.

The type plate of the device can be found behind a white cover; the device's serial number is indicated on the type plate.

This ground source heat pump is CE-marked.

2. Geothermal heating system operation

A geothermal (or ground source) heat pump can extract geothermal heat from soil, water bodies or a bore hole. For an overview of the heat pump and its operating environment, see the picture below. Of the total thermal energy required for heating, Lämpöässä collects more than 75% from natural sources. For thermal energy collection, approx. 25% of electrical energy is required for running the various system components.

The geothermal heating system consists of heat collection piping, water/ethanol (ethyl alcohol) mixture circulating within the piping, and a ground source heat pump unit. The ground source heat pump unit comprises an integrated hot water storage tank, compressor, heat exchangers, and closed refrigerant circuit, i.e., compressor unit. The heat collection fluid in the ground circuit, the refrigerant and the water in the heating network never mix at any stage of the process. Heat is transferred between fluids using plate heat exchangers.

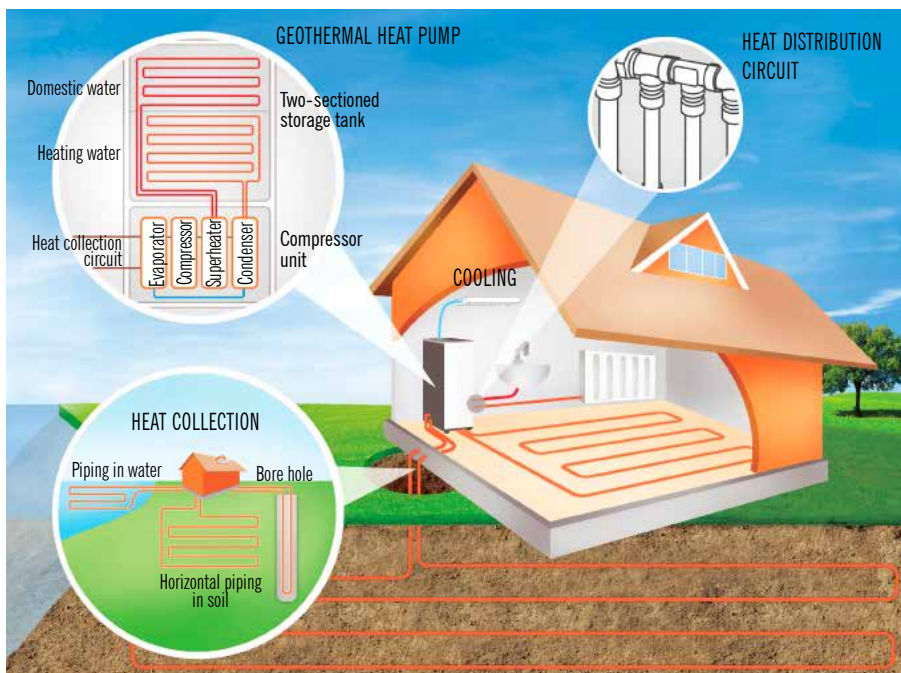

USER MANUAL

2.1 Lämpöässä Vsi series structure and operating principle

The Lämpöässä Vsi series is especially suitable for use as the primary heating system of new and renovated residential buildings and secondary residences, as well as for condominium-specific heating in terraced houses and detached houses. In order to ensure trouble-free operation, all Lämpöässä geothermal heat pumps have been test-run, set up and tested by the manufacturer. If a geothermal heat pump is being used in the part-power configuration, for example, because high temperature is required in the radiator system, the heating system must be dimensioned and adjusted so that the return water temperature is always below +55 °C (conditions in Finland). By part-power we hereby mean that the electric heating element (immersion heater) is allowed to switch on if necessary.

For the operating principle and main components of Lämpöässä Vsi series, see the picture below. The picture has also been discussed in Sections 2.1.1-2.1.3.

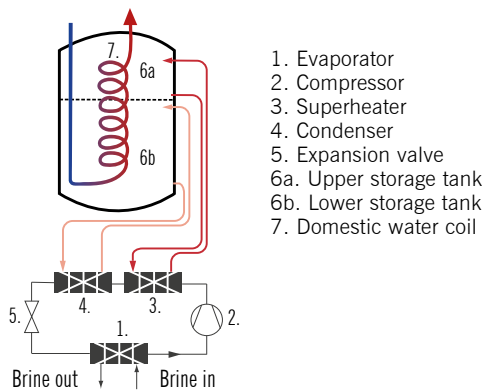

1. Evaporator
2. Compressor
3. Superheater
4. Condenser
5. Expansion valve
- 6a. Upper storage tank
- 6b. Lower storage tank
7. Domestic water coil

2.1.1. Heat collection circuit

The geothermal heat system circulates water/ethanol mixture protected against freezing in the heat collection circuit in order to collect thermal energy accumulated in soil through solar radiation. The heat collection piping used comprises a bore hole or plastic pipe (PEM 40/10) placed at least 1-1.2 metres deep in soil or at least 3 metres deep in water. The circulating mixture warms up by a few degrees and delivers this thermal energy to the geothermal heat pump's EVAPORATOR (1), i.e., the heat exchanger. The temperature of the heat collection fluid arriving from the soil to the evaporator is approx. 0 °C.* This temperature can be lower in winter and higher in summer. At the evaporator, the energy of the heat collection fluid is transferred to the low-pressure refrigerant circulating

inside the heat pump. The refrigerant is evaporated using the thermal energy.

2.1.2. Compressor unit

From the evaporator, refrigerant vapour is transferred to COMPRESSOR (2) for ramping up the pressure. This is accompanied by steep temperature rise. In the course of the heat pump process, the refrigerant temperature is the highest after the compressor, in excess of 100 °C, and the refrigerant is referred to as 'hot gas'.

The hot refrigerant is transferred from the compressor to heat exchangers (condenser and superheater), through which it releases its thermal energy into the heating water storage tank (6). The heat in the storage tank is used for heating and hot domestic water production purposes. When heat is extracted from the refrigerant vapour, a point is reached where the vapour begins to revert into liquid – i.e., is condensed. This point is close to temperature required for heating (in general, approx. 35-55 °C). Since the refrigerant gas leaves the compressor at 70-120 °C, it cools first and liquefies later. The energy released in the course of such cooling is referred to as superheating energy. The superheating energy can be efficiently utilised in final heating of domestic water, by using a superheat exchanger (3).

After the superheater, the refrigerant is transferred to CONDENSER (4), where it is transformed from vapour to liquid, releasing the heat to the heating water storage tank and from there to the heating network. Having conceded its thermal energy, the liquid refrigerant is transferred through dehydration filter to EXPANSION VALVE (5), where the pressure of the liquid refrigerant drops and a new cycle from the evaporator can commence.

2.1.3. Hot water storage tank

Lämpöässä Vsi utilises carefully designed superheating technology allowing advantageous generation of heating and domestic hot water. The objective is to maximise the share of geothermal heat in overall heating. A two-sectioned HEATING WATER STORAGE TANK (6) equipped with partition enhances utilisation of superheating energy. The coefficient of performance remains at a high level, since the energy-efficient superheating mixture involves heat transfer between two tank sections using two different heat exchangers (condenser and superheater).

100% GEOTHERMAL HEAT

USER MANUAL

Water from the hot water storage tank is circulated in the heat distribution piping consisting of either one or two loops.

The top part of the storage tank, i.e. the TOP STORAGE TANK (6a), is heated by using superheat removal heat exchanger (superheater 3) by the extremely high thermal energy acquired from the compressor. Hot superheating energy is stored for final heating of domestic hot water. If required, the high thermal energy can also be transferred to the heating system from the top storage tank.

The LOWER STORAGE TANK (6b) stores the thermal energy required for central heating from the condenser (4) at heating network-adjusted temperatures lower than those of domestic hot water. The storage tank temperature levels are controlled by an adjustment curve – thus, at ordinary heating circumstances, the temperature varies depending on the heating need. In such cases, the system operates in so-called ‘floating condensing’ mode. Heat distribution can be arranged using water circulation-based floor heating, hot water radiators or air heating. The best coefficient of performance is achieved by floor heating, since the lower is the temperature of heat release, the better is the coefficient.

Domestic water is heated within a COIL (7) inside the storage tank, which is divided into two parts. The domestic water is pre-heated in the coil located at the storage tank’s lower part, while final heating takes place inside the coil located at the tank’s upper part. In general, domestic water temperature must exceed that of the heating water. Owing to the two-stage heat release of the superheating technology, the larger storage tank section heating the supply water can be kept at a lower temperature, since final heating of the domestic water takes place using the upper storage tank section of higher temperature. In such a case, the process operation temperatures remain as low as possible, which improves the system’s annual efficiency.

2.2 ÄssäCooling cooling system

A passive cooling system can be installed into the heat collection circuit, in which case the fluid in the circuit is circulated through an additional heat exchanger. The heat exchanger releases cooling energy to indoor air. Such exchangers include radiant cooling units provided within the ventilation system or fan coils installed indoor. The Lämpöässä product family includes wall and ceiling-mounted fan units for cooling, complete with installation set. Passive cooling is a favourable approach to cooling, since the only running costs are associated with water circulation pump and

cooling fan operation.



3. How to use the equipment

3.1. Control system functioning



ÄssäControl by Lämpöässä is a logic-based control system. It considers the conditions prevailing in the premises and the surrounding environment with improved precision. ÄssäControl control system adjusts the heating network supply water temperature proceeding from the storage tank and outdoor temperature based on a seven-point adjustment curve, so that the room temperature remains pleasantly even regardless of outdoor temperature variations.

Depending on the connections, the control system controls 1-3 heat distribution circuits or 1-2 heat distribution circuits and domestic hot water temperature. With the help of the ÄssäControl control system, it is also possible to control an external heat source to the geothermal heat pump unit.

Use the button in the bottom left corner to return to the home screen. Use the arrow button in the bottom right corner to return to previous screen. For instructions screen, press the ‘i’ button in the top right corner. In case of operation faults, an alarm button is displayed on the top bar.

USER MANUAL

These instructions contain a user manual and a manual for equipment installer. Maintenance functions are password-protected.

3.2. Touch screen functioning

After unit start-up the display goes into basic mode, displaying on the two-part ÄssäControl home screen function shortcuts (8 pc.), time, date, and outdoor temperature. To switch between the two home screens, use the arrow buttons in the bottom right corner. To access the Functions screen, press the symbol in the top left corner.

The function shortcuts displayed on the first home screen include room temperature adjustment, domestic water boost, home/away function, and measurements.



The function shortcuts displayed on the second home screen include timer functions, adjustment curve set values, storage tank set values, and optional equipment.



Use the button in the bottom left corner to return to the home screen. Use the arrow button in the bottom right corner to return to previous screen. For instructions screen, press the 'i' button in the top right corner. In case of operation faults, an alarm button is displayed on the top bar.

3.3. Setting the time and date

The time and date can be adjusted by pressing the date/time displayed on the home screen top part.

3.4 Function shortcuts

For user convenience, shortcuts have been provided to functions used most often. Use home screen shortcuts to access the respective functions.

3.4.1. Room temperature adjustment

The heat distribution circuit/circuits' heat curve setting can be adjusted by using the home screen shortcut Room temperature adjustment to achieve room temperature increase or decrease. The setting can be adjusted between -3...+3 °C by using the 'plus' and 'minus' buttons. The function Room temperature adjustment is intended for quick temperature increase. Choose the heat distribution circuits to be influenced by the adjustment by buttons HD1, HD2 (optional equipment) and HD3 (optional equipment). To restore the original setting, change the value to 0 °C. The original heating curve and heating curve adjusted by this function are visible on the Heat adjustment curve screens.

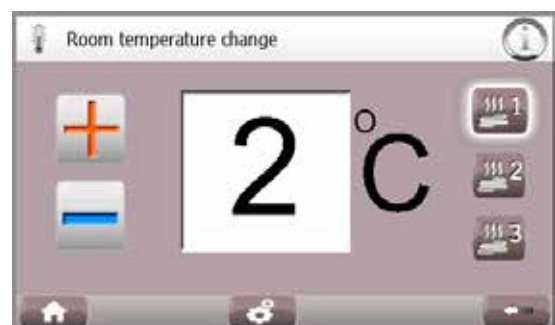

3.4.2. Room temperature adjustment by room temperature measurement (optional equipment)

As an option, the room temperature measurement function can be acquired for the system. In such a case, the room temperature is also displayed on the home screen and the screen Room temperature adjustment includes information on current/target room temperatures. Adjust-

100% GEOTHERMAL HEAT

USER MANUAL

ment of room temperature now takes place by comparing the target and current room temperatures. By adjusting the target temperature higher or lower than the room temperature at the time, the unit adjusts the heat curve in the desired direction. Choose the heat distribution circuits to be influenced by the adjustment by buttons HD1, HD2 (optional equipment) and HD3 (optional equipment).



The rate of the function Room temperature adjustment can be increased 1...7 times by compensation. The compensation function is included under additional room temperature settings, which can be accessed by pressing the button at the bottom centre of the screen. In case of compensation value 7, the adjustment is seven times faster than in case of value 1. Large compensation values can cause room temperature fluctuations.

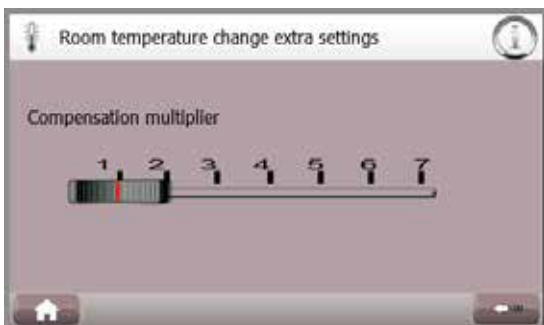

3.4.3. Domestic water boost

The storage tank can be set to function at maximum thermal output in order to meet transient needs, for example, if the need for domestic hot water increases temporarily. For domestic water boost, press the Max button. Return to the normal mode by pressing the Eco button. Choose the domestic water boost period (1...24 h) using the 'plus' and 'minus' buttons.



3.4.4. Home/Away function

The home/away function shortcut can be used to save energy when the residents are away for a long holiday trip, for example. The function Away changes the heat distribution circuit and storage tank temperature settings until the set date and time; after that, the original set values are automatically restored (i.e., the normal mode Home is reactivated).

The system's normal mode is Home. To activate the Away function, press the button Away and set the date and time of your return for restoring the mode Home (default value: 24 h). The changes in room and storage tank temperatures can also be programmed. In order to ensure restoring of the normal temperatures by the time of your return from the holiday trip, the day preceding the actual return date, for example, could be programmed as the return date.



Set the desired heat distribution circuit temperature adjustment under Room temperature adjustment; values between -10...+10 °C are possible. Set the desired storage tank temperature adjustment value under Storage tank temperature adjustment. This setting influences domestic water temperature. Values between -10...+10 °C are possible. If any of these temperatures is not to be changed, keep 0 °C as its value. When leaving for a holiday trip, for example, both of the values might be lowered by approx. 5 degrees by setting -5 °C as the room/storage temperature adjustment value.

Use the button in the bottom left corner to return to the home screen. Use the arrow button in the bottom right corner to return to previous screen. For instructions screen, press the 'i' button in the top right corner. In case of operation faults, an alarm button is displayed on the top bar.

USER MANUAL

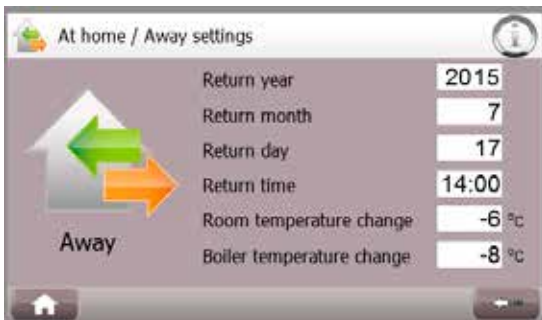

The function can be activated only if the end date or time is in the future. If the end date is set into the past, the mode Home is activated and the mode Away cannot be activated.

3.4.5. Measurements

This shortcut allows accessing the Measurements menu, which will be discussed in more detail in the Section on menu functions.



3.4.6. Timer functions

Timer functions can be utilised, for example, in secondary residences or to benefit from off-peak electricity rates, in which case weekday-specific modification of temperature levels is advantageous. The values once set are saved in the memory and can be modified as necessary. The timer function can be activated or removed from use through the **Timer functions** shortcut.

On the **Timer functions** screen, the timing target (storage tank or heat distribution circuit) is selected and the timer function activated/deactivated.



On the following screens, the target weekdays for timed temperature changes are selected. On the screens, the temperature change beginning and end times (in full hours) can be set in weekday-specific manner, as well as the change in degrees. Temperature change values between -10...+10 °C are possible. The last timing column consists of symbols



describing the state of timing. A white symbol means that there is no active timer setting for the weekday. A yellow symbol means that time and temperature have been set, but the timer function has not been activated. A green symbol means that time and temperature have been set and the timer function has been activated.

100% GEOTHERMAL HEAT

USER MANUAL

3.4.7. Adjustment curves

This shortcut allows accessing the Adjustment curves menu, which will be discussed in more detail in the Section on menu functions.



3.4.8. Storage tank settings

This shortcut allows accessing the Storage tank settings menu, which will be discussed in more detail in the Section on menu functions.



3.4.9. Optional equipment

This shortcut allows accessing the Optional equipment menu, which will be discussed in more detail in the chapter on menu functions.



3.5. Menu functions

Menu functions can be accessed by pressing the menu button on the home screen.

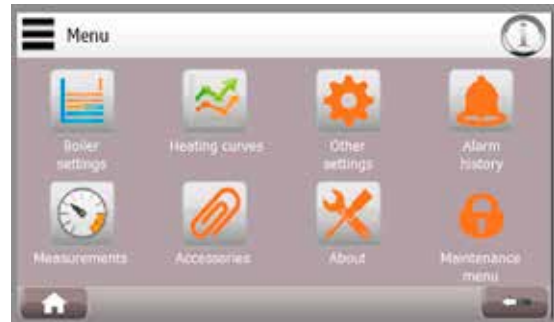

3.5.1. Storage tank settings

Storage tank set values are used to adjust the storage tank top and bottom section temperature limits to meet the site's domestic hot water consumption. The system includes a function that automatically elevates storage tank temperature if the heat distribution circuit adjustment curves are set higher than the storage tank temperature. Factory settings for the storage tank bottom section are 40 °C (min) and 45 °C (max). Factory settings for the storage tank top section are 50 °C (min) and 55 °C (max). The difference between Min and Max values can be 2...10 °C. The maximum allowed storage tank top and bottom section temperature set value is 60 °C in case of full power geothermal heat pumps and 60 °C (bottom section) / 85 °C (top section) in case of part-power geothermal heat pumps.

The value Correction indicates the temperature as corrected by the Timer function, Home/Away function, Domestic water boost function, or automatic heat distribution circuit correction.



Use the button in the bottom left corner to return to the home screen. Use the arrow button in the bottom right corner to return to previous screen. For instructions screen, press the 'i' button in the top right corner. In case of operation faults, an alarm button is displayed on the top bar.

USER MANUAL

The storage tank temperature is a decisive factor in compressor starting and stopping. The minimum value programs compressor starting at the storage tank's target temperature. The maximum value programs compressor stopping at the storage tank's target temperature.

The storage tank is heated by the compressor. If the target temperature cannot be reached in a certain time (1...24 h), it is presumed that there is something wrong with the compressor and the compressor is turned off. In such cases, the storage tank is heated by the electric heating element. The default set value for this function is 12 h. If the electric heating element is switched on, the following warning is displayed on the control panel display: Storage tank temperature not achieved in set time. Electric heating element has been switched on.

Maximum annual ground source heat pump efficiency can be achieved if the storage tank temperature is kept at an optimal level. The ground rule is that the storage tank set values must be kept at the lowest possible level, since it allows the best annual efficiency.

In winter, when the need for heating is larger, the set value for the storage tank bottom section should be programmed in relation to the supply water temperature. The temperature of the storage tank upper part increases after a long period of use and the threshold value for the compressor to run is 90 °C. This is due to the superheating properties of the storage tank structure. Because of this, the domestic hot water temperature limiting function (option) can be used in order to avoid potential hot water-related hazards. In general, the compressor is controlled according to the minimum setting of the storage tank lower part.

In summer, when there is no need for heating (with the exception of humid rooms), the compressor is seldom on and there is less superheating for domestic hot water production. In such a case the storage tank upper part and lower part temperatures are close to each other.

3.5.2. Adjustment curves

Heat distribution circuits (HD) are controlled by a seven-point adjustment curve. Depending on the connections, the control system controls 1-3 heat distribution circuits or 1-2 heat distribution circuits and domestic hot water temperature. In the Adjustment curves menu, the values of all heat distribution circuits can be changed separately to meet the heating water temperature (supply water) at a certain outdoor temperature.

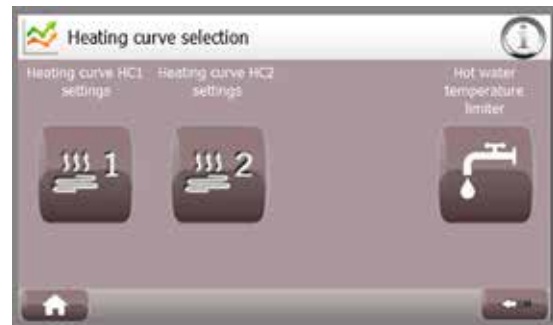

Exemplary floor heating adjustment curve (factory setting) °C*

Outdoor temperature	-20	-13	-7	0	+7	+13	+20
Heating water temperature	+32	+31	+29	+27	+25	+23	+21

Exemplary radiator heating adjustment curve °C*

Outdoor temperature	-20	-13	-7	0	+7	+13	+20
Heating water temperature	+53	+48	+42	+36	+30	+25	+21

* Conditions in Finland.

The factory-set adjustment curve is suitable for floor heating. The adjustment curve values should be specified during the first year; they could be changed as follows, for example: If the indoor temperature feels too chilly while the outdoor temperature is -10 °C, the supply water set value can be increased a little at the outdoor temperature points -13 °C and -7 °C. Monitor the influence of the adjustment on room temperature for at least 24 hours before making any further modifications in adjustment curve set values. When using radiator heating temperature change is quicker.

For the temperature correction caused by Home/Away or Timer functions, see the bottommost line.

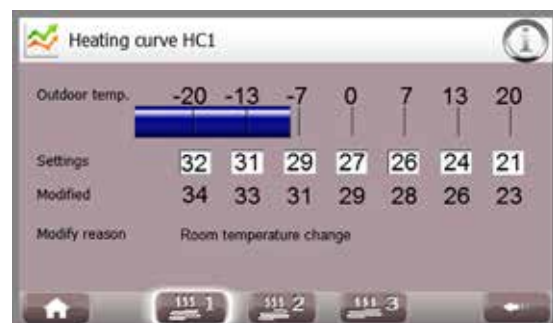

Use the button in the bottom left corner to return to the home screen. Use the arrow button in the bottom right corner to return to previous screen. For instructions screen, press the 'i' button in the top right corner. In case of operation faults, an alarm button is displayed on the top bar.

100% GEOTHERMAL HEAT

USER MANUAL

Maximum domestic water temperature can be limited by adjusting the Domestic water temperature limit value between 0...90 °C (factory setting: 55 °C).

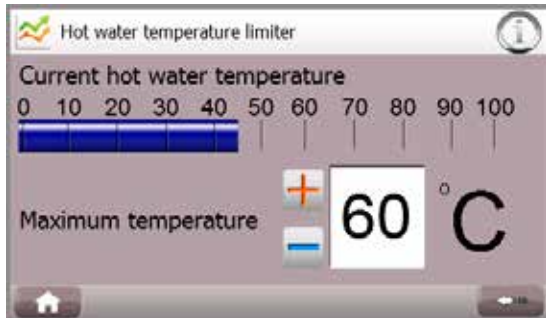

3.5.3. Other set values

The menu Other set values allows circuit-specific programming of maximum and minimum heat distribution circuit supply water values, as well as programming of the safety device-heating element activation time.



3.5.3.1. Language

The Language menu allows choosing between Finnish, Swedish and English for the user interface language.



3.5.3.2. Screen settings

On screen settings -page it is possible to adjust the brightness of the screen and also the time after the screen goes off.

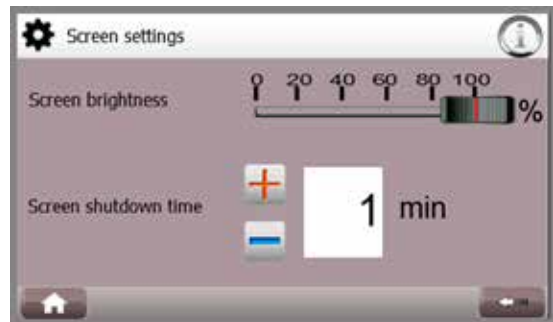

3.5.3.3. Min and max temperature of HD circuits

Set values are minimum possible values (min) and maximum possible values (max). Heat distribution circuits 2 and 3 are optional.

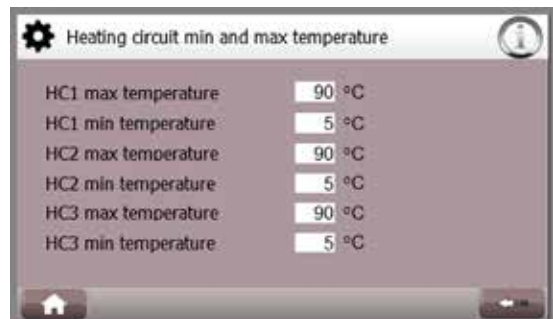

Factory settings for heat distribution circuits are as follows:

Set value and setting range	Meaning	Factory setting
Supply water1 max 0...90 °C	Maximum value of heat distribution circuit 1 heating supply water.	60 °C
Supply water1 min 0...90 °C	Minimum value of heat distribution circuit 1 heating supply water.	5 °C
Supply water2 max 0...90 °C	Maximum value of heat distribution circuit 2 heating supply water.	60 °C
Supply water2 min 0...90 °C	Minimum value of heat distribution circuit 2 heating supply water.	5 °C
Supply water3 max 0...90 °C	Maximum value of heat distribution circuit 3 heating supply water.	60 °C
Supply water3 min 0...90 °C	Minimum value of heat distribution circuit 3 heating supply water.	5 °C

Use the button in the bottom left corner to return to the home screen. Use the arrow button in the bottom right corner to return to previous screen. For instructions screen, press the 'i' button in the top right corner. In case of operation faults, an alarm button is displayed on the top bar.

USER MANUAL

3.5.3.4. Safety device settings (in monovalent devices)

This screen allows programming activation of the safety device-heating element if the storage tank target temperature is not achieved by the compressor during the dedicated period (from 0 to 24 hours, factory setting: 12 hours). The setting is applicable in full-power systems only.



3.5.3.5. Bivalent settings (in bivalent devices)

In bivalent system the immersion heater and compressor can be on at the same time. In bivalent settings -page can be set the heating time before additional heating goes on.



3.5.3.6. Summer function

In this screen months when function is valid and circulation pumps active are selected. To avoid circulation pumps to be stucked they automatically start up every week for 30 seconds. Here you can also validate heating circuits where summer function is effecting. Circuit can be active during a whole summer when it is controlling bathroom area for example.

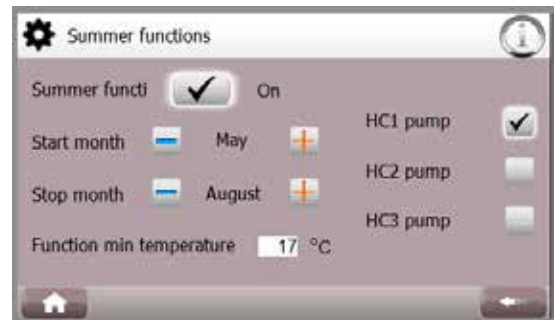

3.5.3.7. Brine circuit circulation pump control

This screen allows adjustment of the ground circuit fluid flow rate. If the setting is 100%, the flow speed is maximal. If the setting is 0%, the flow speed is off. Factory setting: 90%.

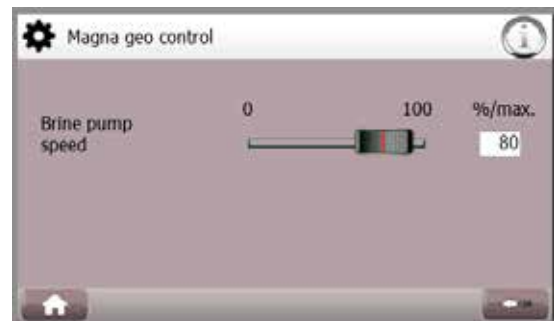

3.5.3.8. Passive cooling

There is a possibility to install cooling system to the heat pump brine collector circuit. Brine collector liquid is circulated through cooling system installed in to the premises. Passive cooling is energy efficient method of cooling as the only cost is electrical consumption of the circulation pump and cooling convector fan.

Room temperature control

In this screen operational area of the cooling system is adjusted. In addition of this in the screen there are values for room temperature, liquid temperature, humidity and dew point indicated. Also status of the system (heating/cooling/turned off) is informed.

100% GEOTHERMAL HEAT

USER MANUAL

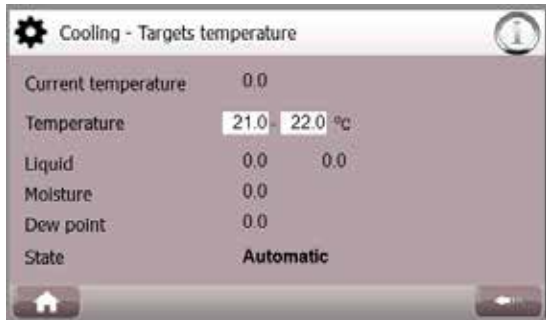

External control

When controlling method is external cooling is controlled by external thermostat which to be connected according the electrical drawing.

Manual control

When controlling method is manual can cooling be activated in this screen. System aims to maintain cooling liquid temperature one degree above the dew point. Cooling liquid temperature can also be adjusted to be standard when dew point effect is not recognized.

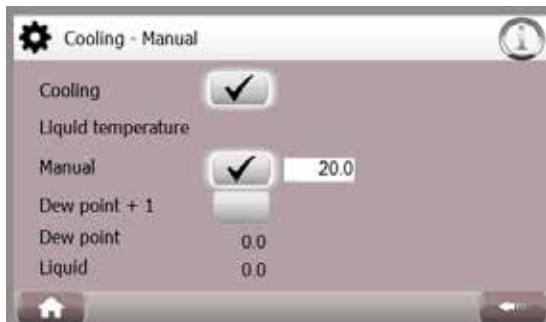

3.5.4. Measurements

Ground source heat pump operation can be monitored using various different measurement data. Use the screen numbering in the bottom bar for navigating between the Measurements screens. Measurements screen values describe heat pump operation under various conditions and the values shown cannot be modified. The left-hand column indicates current measurement values and the right-hand column the respective set values. Measurement results from all sensors, compressor running times, and

electric heating element operation times can be browsed.

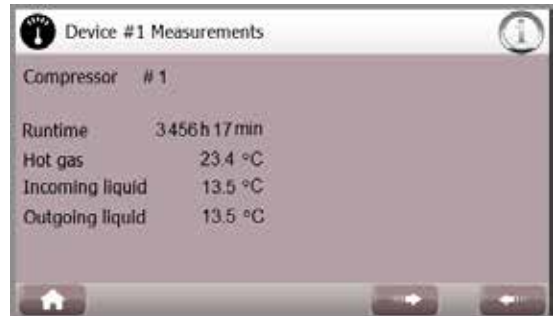
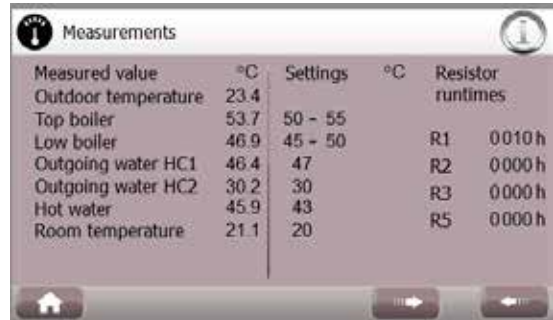

3.5.5. Optional equipment

In addition to the standard delivery, all of the additional features acquired are displayed on the Optional equipment screen.

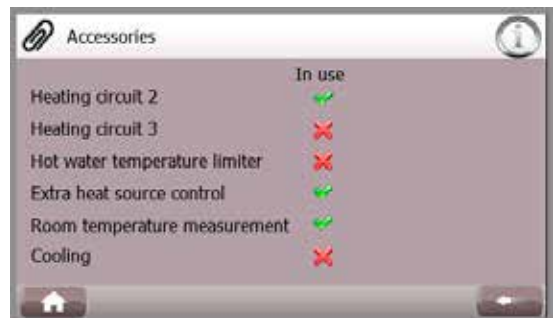

Possible optional equipment includes:

Optional equipment	For more information, see
Heat distribution circuit 2	Adjustment curves, Timer functions
Heat distribution circuit 3 or Domestic water temperature limit	Adjustment curves, Timer functions Adjustment curves
Room temperature measurement	Shortcut functions, Adjustment curves
Passive Cooling	Adjustment curves

Use the button in the bottom left corner to return to the home screen. Use the arrow button in the bottom right corner to return to previous screen. For instructions screen, press the 'i' button in the top right corner. In case of operation faults, an alarm button is displayed on the top bar.

INSTALLER MANUAL

4. INSTALLATION WORKS

4.1. Before installation

Pipe assemblies for the installation of the Lämpöässä system may only be installed by qualified and trained persons. The equipment must be installed in compliance with instructions provided; after performance of installation works, the installation checklist must be reviewed in order to minimise potential errors. The manufacturer shall not be responsible for any equipment defects or related expenses caused through installation faults.

Check that:

- all the necessary hoses and sensors have been delivered
- the ground source heat pump has been correctly fitted
- the connections on top of the geothermal heat pump are intact
- the fuse size is correct for the master fuse and the ground source heat pump (see technical specifications)
- the ground circuit collection piping and supply piping have been installed properly

4.1.1. Transport

The Lämpöässä geothermal heat pump must always be transported in a vertical position. If tilting the equipment is unavoidable, for example, to pass through a doorway, the maximum tilting angle allowed is 45°. In other cases, the machine's compressor unit must be detached during tilting. The equipment may be moved from beneath using a fork lift, for example. Do not go underneath the equipment while it is being lifted! A transportation platform has been fastened on both sides of the ground source heat pump using screws. The ground source heat pump's accessory package includes adjustable feet to be screwed into the unit bottom (see picture). After that, remove the wooden platform elements and their fixation screws (4 pc). To remove the platform, lift the equipment by a fork lift, for example.

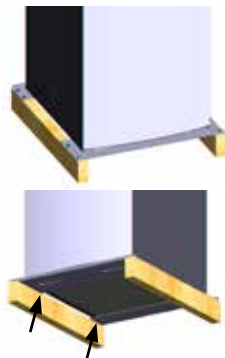

4.1.2. Ground source heat pump installation area

We recommend that the Lämpöässä ground source heat pump be installed in a warm room with floor drain. During installation, when filling the ground circuit, some water/ethanol or water/glycol mixture may be splashed onto the floor. The chosen area does not have to be fireproof. Approx. 30 cm of installation space should be reserved above the equipment. For more specific space requirements, see pre-instruction manual.

The floor must be able to withstand the weight of the ground source heat pump carrying a full storage tank (= own weight + 300 kg). The floor must also be sufficiently even, because the ground source heat pump must be installed as level as possible. Final adjustments can be made using the adjustable underneath the equipment.

4.1.3. Removing the packaging

Remove the plastic wrapping and corner padding from around the product. Check that the pump has not suffered any transportation damage. If the heat pump is found to be damaged, the transport company must be immediately notified.

Also check the contents of the delivery immediately. The Lämpöässä Vsi series accessory package includes the following components:

- 2 x flexible pipes (approximately 600 mm)
- Outdoor sensor
- 4 x adjustable feet
- Ground loop fill
- Fill bottle + spare valve

If some of the accessories specified in the order are not included in the delivery, notify the equipment dealer within five days.

4.1.4. Space requirements

A Lämpöässä Vsi series ground source heat pump can conveniently be placed into a technical or utility room. The floor space to be reserved for the machine needs not significantly exceed its external dimensions. Approx. 50-60 cm of installation room should be reserved on the respec-

100% GEOTHERMAL HEAT

INSTALLER MANUAL

tive side for lateral ground circuit connections. Considering possible equipment maintenance, there must be approx. 70 cm of free space in front of the geothermal heat pump. The height of a Lämpöässä Vsi series ground source heat pump (including adjustable feet) is at least 183 cm. The transport platform adds some 8 cm. Approx. 30 cm of free space must be reserved for connections on top of the machine. This should be kept in mind when installing the equipment into a low room, such as basement.

Vsi 6 - 14 space requirement (mm)

A	50 / 500	
B	50	
C	500 / 50	
O	700	
X	1150	
F	700	
Y	1300	

4.2. HVAC installation

4.2.1. Heat collection circuit and fill group installation

On both sides of the geothermal heat pump there are places designated for the heat collection circuit pipes. Remove the flaps on the side required for the lead-through. Install the external pipe (added to the equipment package) between the heat collection pipeline's circulation water pump and the flexible pipe (right/left). The joint must be done really carefully.

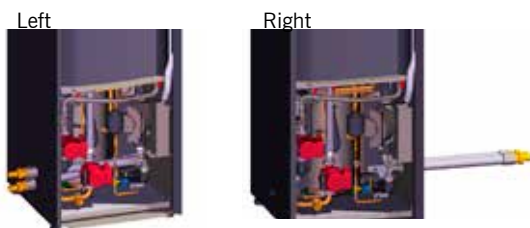

Install the fill and de-aeration group on the return side of the heat collection circuit according to the drawing.

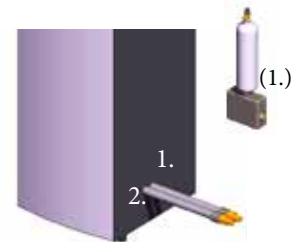

1. Heat collecting, return
2. Heat collecting, flow

In case a cooling system is attached to the geothermal heat pump, situating on top of the heat pump, a surface expansion tank must be added to the system. In such cases, an aeration joint will be installed in the highest point of the system; and the fill bottle will be removed from use by closing the closing valve on its lower side.

4.2.2. Filling and de-aeration of the heat collection circuit

Accessories required for the filling and de-aeration of the ground circuit:

- mixing tank, 60 litres
- submersible pump fitted with a filter, lifting height approx. 30 m
- water/ethanol or water/glycol mixture (1:1) with a frost resistance of -16 °C
- reinforced hose 1" (2 pc.), length approx. 3 m
- connector 3/4" (female thread) for reinforced hose
- connector 1" (female thread) for reinforced hose

WORK STAGES

Please check that the ground circuit has been correctly connected.

1. Remove the styrox packaging protecting the group of fill valves.
2. Detach the expansion vessel from the foremost ball valve.
3. The foremost shut-off valve (2) of the group of fill valves must always be open.
4. Attach the submersible pump textile hose to the foremost ball valve (3) in the group of fill valves and open the ball valve.

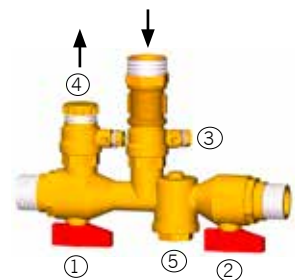

5. Attach a textile hose from the ball valve (4) at the back of the group of fill valves to the fill container and open the valve.
6. Fill the container with water/ethanol or water/glycol (frost r. -16 °C) mixture (ratio 1:1).
7. Bleed air from fill hoses by activating the submersible pump and keeping the valve (1) open. When air has escaped, close the valve (1) to start actual fluid circulation through the ground circuit.

INSTALLER MANUAL

8. Add fluid until the piping is full. Upon de-aeration, the unit's own brine circulation pump can be used to speed up fluid circulation.
- Check that the motor protection switch (QM1) is not on.
 - Turn master switch (Q1) and control current switch (F10) on.
 - The forced control of ground circuit pump can be activated from the maintenance manual of AssäControl. Go to manual control and choose manual control on and ground circuit 1 on.

NOTE! When using the system's own brine circulation pump for de-aeration purposes, check that the flow direction of the separate submersible pump is always the same as that of the unit's pump.

9. Keep the submersible pump running until the fluid is clear and no gurgling can be heard from the pipes. NOTE! De-aeration usually takes several hours and helps to ensure that all the air is removed from the system and will not cause any malfunctions once the system is started. Leave no pressure in the network! Remove any air from the evaporator through the de-aeration connection of the pipe located between the ground circuit and the evaporator.
10. When de-aeration has been completed turn the manual control function off.
11. Open the shut off valve (1) at the back of the group of fill valves
12. Close both ball valves (3) and (4).
13. Remove the fill hoses.
14. Fasten the expansion vessel back in its place in the foremost ball valve (3) in the group of fill valves.
15. Remove the safety valve on the expansion vessel.
16. Fill $\frac{3}{4}$ of the expansion vessel with water/ethanol or water/glycol mixture.
17. Fasten the safety valve to the expansion vessel.
18. Open the foremost shut-off valve (3) in the group of fill valves.
19. Remove and clean the net strainer (5) on the mud separator, repeat this several times, if necessary. The red-handled valves (1) and (2), as well as the valve under the fill container (3) must be closed in order to prevent fluids from running out.

Filling and de-aeration have now been completed.

4.2.3. Heating and domestic hot water connections

Remove the crown panel from the geothermal heat pump's upper part for the duration of installation works by undoing the two screws shown in the picture. Pull the crown panel directly forward and lift it off the heat pump. Make the heat distribution and domestic water connections as shown in the picture.

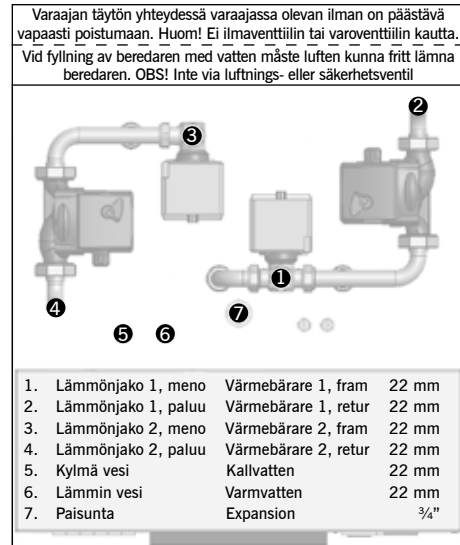

Heating connection

Heat distribution circuit surface sensors located on top of the storage tank must be installed to the distance of approx. 0.5 m from the three-way or four-way valve. Circuit HD1 is always the main heating circuit (rooms, for example); it is used for higher temperature (radiator heating, for example). In case of compressor malfunction, the electric heating element heats the circuit HD1 more efficiently. Circuit HD2 is used in radiator-heated buildings for the possible floor heating share or for other purposes (e.g., humid rooms).

Speed controlling of the heat circulation pumps

Grundfos UPM3 AUTO heat circulation pump which is used in a HD circuit can be set in three different controlling modes: proportional pressure mode, constant pressure mode, constant curve mode. **Factory setting is proportional pressure mode 3.** In radiator network constant pressure mode 1 or 2 can be used if sound of the flow water is disturbingly high.

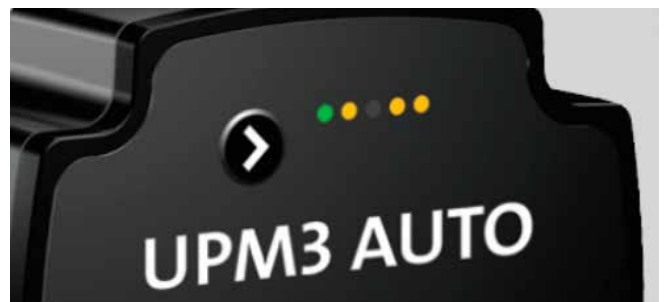

100% GEOTHERMAL HEAT

INSTALLER MANUAL

Proportional pressure mode	LED1 green	LED2 yellow	LED3 yellow	LED4 yellow	LED5 yellow
Proportional pressure mode 1					
Proportional pressure mode 2					
Proportional pressure mode 3					
Auto Adapt					

Constant pressure mode	LED1 green	LED2 yellow	LED3 yellow	LED4 yellow	LED5 yellow
Constant pressure mode 1					
Constant pressure mode 2					
Constant pressure mode 3					
Auto Adapt					

Constant curve mode	LED1 green	LED2 yellow	LED3 yellow	LED4 yellow	LED5 yellow
Constant curve mode 1					
Constant curve mode 2					
Constant curve mode 3					
Constant curve mode 4					

The storage tank is to be filled with special care through the group of fill valves included in the system so that the storage tank pressure never exceeds 1.5 bar. While filling the storage tank, the air inside it must be allowed to escape freely and not through air valve or safety valve, for example. Suomen Lämpöpumpputekniikka Oy cannot be held responsible for any expenses resulting from storage tank breakage in situations where the tank has not been filled with water pursuant to the above instructions.

NOTE! Maximum storage tank pressure is 1.5 bar!

The pipes in the heating network are connected to the ground source heat pump using either textile hoses (network of radiators) or using a fixed piping network (floor heating). These connections prevent sound from passing into the network. All heating connections (for example, a heating radiator for an air conditioner or a heated towel rail) must be made to the heat distribution circuits, not domestic hot water. When the network piping is in place, filling may commence.

Storage tank and heating system filling and de-aeration

There must be a de-aeration valve in the same branch with the group of fill valves. The expansion vessel may be in the same branch as well. The pipes in the network are filled with water. Note! If renovating, ensure that the heat distribution piping has been properly rinsed before connecting the geothermal heat pump.

Filling and de-aerating a heating system fitted with a pressure gauge:

- Open the fill valve on the heating network.
- Fill the network with water.
- De-aerate the storage tank and network until all the air has been removed and leave the pressure at 1-1.2 bar (max. 1.5 bar).
- Maximum pressures:
- Heating network storage tank – 1.5 bar
- Domestic hot water circuit – 9 bar

Domestic hot water connections and circulation of water

If there is no domestic hot water circulation at the site, make connections pursuant to HVAC diagrams annexed to these instructions. Domestic water is connected to the ground source heat pump pursuant to the picture in Section 4.2.3. The same picture is provided on top of the unit. The mixing valve is fitted to the hot water pipe in order to prevent burns. The overflow pipe is joined to the floor drain as instructed or to an overflow funnel if the distance to the floor drain is more than two metres. The overflow funnel must be directed down towards the floor drain. The back-pressure valve is fitted to the cold water joint on the input side. See the annexed HVAC connections diagram.

If there is domestic hot water circulation at the site, we recommend installation of a small additional heat source (e.g. ÄssäStrem or 30I ÄssäStrem domestic hot water storage tank). This is to ensure the optimal operation of ground source heat pump. See the picture.

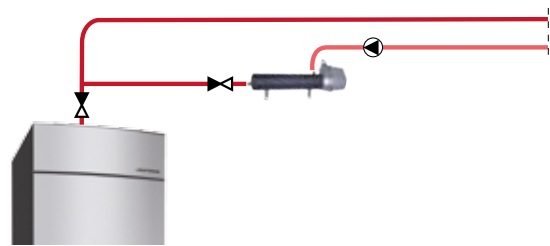

NOTE! External radiators or dryers may not be connected to domestic hot water circulation!

4.2.4. HVAC checklist

Check that

- the joints are tight and there are no leaking valves
- the expansion vessel on the heating system and fill side is properly installed

INSTALLER MANUAL

- the overflow pipe on the safety valve and the pressure gauge on the heating system have been properly installed
- the heating system has been filled and de-aerated appropriately
- the ground circuit has been installed, filled and de-aerated appropriately

4.3. Electrical installation and outdoor sensors

Only qualified electricians are permitted to carry out electrical work on the heat pump according to general regulations.

Unit	Power supply	Fuse size, slow, A (*in case of part-power)
Vsi 6	400V 3N~	3x10 (*16)
Vsi 8	400V 3N~	3x16 (*20)
Vsi 8 1x230V	230V 1N~	1 x 25
Vsi 10	400V 3N~	3x16 (*20)
Vsi 12	400V 3N~	3x16 (*20)
Vsi 12 1x230V	230V 1N~	1 x 32
Vsi 14	400V 3N~	3x16 (*20)

The Lämpöässä heat pump is connected to a 400 V (50 Hz) electrical network. The Lämpöässä heat pump has been fitted with an integrated electrical switchboard which is permanently powered. A plastic-coated wire is used as a supply line, which wire travels to the master switch in a casing pipe. The electrical switchboard cover can be removed without crown panel removal, by undoing four screws on top of the switchboard. Removing instructions of the crown panel can be found in a section 4.2.3

4.3.1. Outdoor sensor

In order for the outdoor sensor to recognise weather conditions as effectively as possible, it must be placed in the correct location. The outdoor sensor should be placed on the north-western or northern side of the building to avoid the effects of the morning sun. If the sensor cannot be placed as recommended, ensure that this is protected from direct sun light.

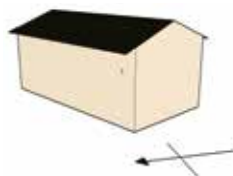

The sensor is placed approximately 2/3 of the way up to the wall of the building near the corner. A sensor should not be placed under a roof, in a place protected from the wind or over a vent, doors or windows where the temperature is not the normal outdoor temperature.

Device	Terminal block No.	Conductor type
--------	--------------------	----------------

Outdoor sensor NTC	X1/10 ja X1/2	2 X 0,7 mm ²
--------------------	---------------	-------------------------

4.3.2. Room sensor (optional)

In order for the room sensor to detect average indoor temperatures as reliably as possible, it must be placed in a central and open location, for example a hallway between several rooms or the staircase. String a bipolar electrical line (at least 0.5 mm²) from the heat pump to the room sensor. Position the room sensor approximately 2/3 of the way up the wall. Connect the room sensor lead to the heat pump.

Device	Terminal block No.	Conductor type
Room sensor NTC	X1/14 ja X1/2	2 X 0,7 mm ²

4.3.3. Current monitor

If the equipment has been installed in the part-power configuration, load limiting relays must be installed to the building's master electrical switchboard, if necessary. These relays are intended to reduce the power of the ground source heat pump's electric heating element by phases if the phase current passing through the building's master fuses approaches the master fuse nominal current.

Load limiting relays are connected downstream of the master electrical switchboard's master fuse so that the entire building's main current passes through the relays. Contact data of load limiting relays are wired by quadrupole cable from the master switchboard to the ground source heat pump electrical switchboard, where they are connected to the control circuit diagram. The load limiting relay circuit diagram has been annexed to these instructions. In addition of this contactor K3 should be replaced with three single phase contactors.

100% GEOTHERMAL HEAT

INSTALLER MANUAL

Current monitoring relay installations and connection

These settings are initial and may require changing. Relays must always be adjusted in a case-specific manner.

- Choose correct current range
 - Turn switch 2 to position ON (if master fuse size is less than 50 A)
 - Other switches 1, 3-6 to position OFF.
- Adjust hysteresis, current % and delay using screws in the front part (master fuses 25 A)
 - Hysteresis 21
 - Current 25 - 28 %
 - Delay 1s
- The relay requires external voltage 24-240 V/AC.
- External supply is connected to terminals A1 and A2.
- Terminals 15 and 16 are connected to geothermal heat pump and interrupt the heating element's supply with respect to the phase the current value of which is exceeded.
- Each phase must be lead through the relay using the dedicated hole inside it.
 - L1 for relay 1
 - L2 for relay 2
 - L3 for relay 3

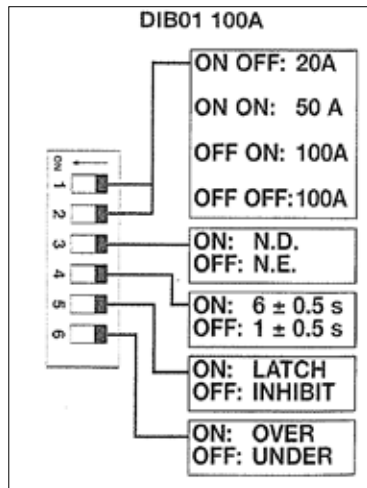

No other connections with relay are necessary.

4.3.4. Electrician's checklist

Check that

- all phases going to the switchboard are in the correct phase sequence
- the master fuse is of sufficient size
- the ground source heat pump's fuse size is correct, type: slow (C curve)
- if necessary, current monitor has been installed to the building's master electrical switchboard (part-power models)

4.4. Commissioning

Before commissioning, check that:

- the heating system has been connected, filled and de-aerated appropriately
- the ground circuit has been installed, filled and de-aerated appropriately
- electrical connections have been made appropriately and the outdoor sensor (and optional room sensor) has been installed
- after preventing the compressor from starting, water in the storage tank has been heated by the electric heating element for at least 6 hours

If the ground source heat pump is started for the first time without pre-heating, compressor will be damaged. Fill the storage tank with water and prevent the compressor from starting by pressing down the red compressor motor circuit breaker. Switch on the ground source heat pump's power supply, the electric heating element begins to heat the water contained in storage tank. A regulator alarm goes on and the text "Compressor 1 circuit 1 some motor protection gone off. Check motor protection F1, F2 or F3" appears on the display. Later another regulator alarm goes on and the text "Resistor functioned in full power system" appears. These alarms do not require taking any measures. Starting of the compressor is allowed after six hours of pre-heating.

NOTE! The ground source heat pump started without pre-heating is not covered by warranty!

INSTALLER MANUAL

Possible problems during startup

Problem	Cause	Solution
Fuses always blow when the compressor is started.	You are using the wrong type of fuse.	Check that the fuse is automatic: C or D / ceramic fuse: SLOW or with a snail icon.
	Temporary connections at the site are causing an overload of the fuses	Reduce load.
The heat collection circuit pump does not start.	The regulator may not be getting any power.	Check the regulator fuse.
	The regulator is not authorised to start the pump.	Check the measured/set values.
	The shut-off valves are in the fill position.	Check that the de-aeration and fill valves are in the closed position and that the intermediate valve is open.
	The heat collection circuit's water circulation pump motor protection switch has gone off.	Reset the motor protection switch and check the set values from electrical diagram.
The compressor runs for a little while and the evaporator pressure switch goes off.	There may still be air in the heat collection circuit.	De-aerate the heat collection circuit.
	There may be a leak in the refrigerant circuit.	Contact the equipment installer or dealer.
The fluid level in the heat collection circuit fill container drops suddenly after startup.	There is a leak in the system (the smell of ethyl alcohol or glycol is strong), there is a leak in the heat collection circuit or there is still air in the circuit.	Check the condition of valves in the de-aeration group, air valve and the shaft seal on the ground circuit pump, check the condition of heat collection circuit extension joints, or de-aerate.
Motor protection switches go off when starting.	The compressor or the ground circuit pump is short-circuited or one of the phases is not activated.	Check electrical connections.
	The fuses in the master switchboard of the building have blown or are faulty.	Check and replace fuses as required.

The maintenance menu section Manual control allows manual control of compressors, pumps and valves. This facilitates troubleshooting process and may be of help in case of starting problems.

100% GEOTHERMAL HEAT

MAINTENANCE MANUAL

5. MAINTENANCE

5.1. Maintenance and care

The Lämpöässä ground source heat pump is an easy-care and reliable heating system that does not require regular maintenance. If the installation is carried out with care and in accordance with the instructions provided, there is usually no need for maintenance. The fill container and mixture circuit filter should be checked every couple of weeks during the first few months and afterwards approximately once a month for the first year of use thereafter.



Lämpöässä heat pumps which includes 3-6 kg refrigerant are hermetically sealed and therefore annual inspection is not required. You are offered the possibility of concluding an agreement on periodic inspections, in connection with which the operation of the Lämpöässä heat pump is covered stage by stage. The observations are registered in the inspection record and necessary measures taken (such as adjustments, for example). For additional information on the periodic inspection agreement, visit hulto@lampoassa.fi.

5.2. Possible problems occurring during use

Problem	Possible cause	Solution
The compressor does not start.	The water tank temperature is adequate and in accordance with the regulator.	No action required.
	The compressor has been stopped for less than 1 minutes.	No action required.
	Fuse problem.	Check the condition of the fuses in the master switchboard.
	Incorrect power supply phase sequence.	Contact an electrician.
The compressor does not start and the display reads Incorrect phase sequence or Motor protection switch gone off.	Incorrect power supply phase sequence.	Contact an electrician.
	The motor protection switch has gone off.	Check the motor protection switch adjustment values, set the motor protection switch to Start position and acknowledge the alarm text displayed. If the fault is not cleared, contact an electrician.

The compressor does not start and the display reads Low pressure switch gone off or High pressure switch gone off.	The low pressure switch has gone off.	Check functionality of the brine circuit pump by running it through the maintenance menu and acknowledge the alarm text displayed.
	The high pressure switch has gone off.	Check functionality of the condenser pump by running it through the maintenance menu and acknowledge the alarm text displayed.
The compressor does not start and the display reads "Compressor 1 circuit 1 some motor protection gone off. Check motor protection F1, F2 or F3".	The motor protection switch has gone off.	Press down the motor protection switch.
	The suction pressure switch on the pressure switch has gone off.	Set off the switch.
No text is visible on the display.	The device is not getting any power.	Check that that the control current and master switches are on.
	A fuse has blown.	Check the building's master fuse and heat pump supply fuse.
	The display is damaged or the display cable loose or damaged.	Contact maintenance
The system does not produce enough heat.	A sudden drop in outdoor temperature may temporarily cause inadequate heating power in new buildings, because moisture contained in the structure takes up a lot of heat when it dries.	No action required.
	During the first year, the ground circuit may not produce heat at full power because the earth around the ground circuit pipes has not yet become more solid.	No action required.
In the Measurements screen, the set value and measured value do not match.	Some active correction function (for example, timer or home/away) is adjusting the original set value.	The active correction function can be deactivated, if required.
	A spiking over-voltage caused by a lightning strike has caused a fault in the regulator (not under warranty), causing the temperature to drop from the actual values.	Replace the regulator (not under warranty).
	The regulator motor has been set on manual and the regulation does not take place.	Return the heat distribution circuit adjustment motor to automatic mode.
The compressor is on all the time or for long periods of time.	In summer, when the building indoor temperature exceeds the value adjusted, the supply water temperature sensor indicates higher readings as compared to the adjustment curve, due to rise in the heat distribution circuit temperature.	No action required.
	A lot of heat is needed, for example the outdoor temperature is very low or the structure is drying during the first year's use of the building.	No action required.
	Lack of refrigerant. Can be detected from bubbles in the liquid container even after some minutes of use.	Contact a refrigeration supplier or maintenance

If these instructions do not help, please contact your local dealer.

MAINTENANCE MANUAL

5.3. Alarms

There are two ways to examine the alarms with ÄssäControl.

- You can see the active alarms if you press the alarm bell on front page. You can check out the alarms by pressing the check out alarms -button. You can go to alarm history from active alarms page by pressing the button at the bottom of the page.

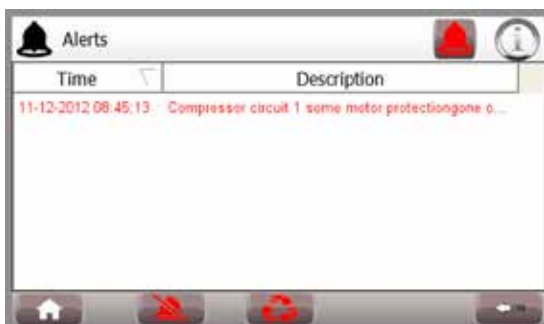

- You can see earlier alarms by pressing the alarm history -button at the menu functions.

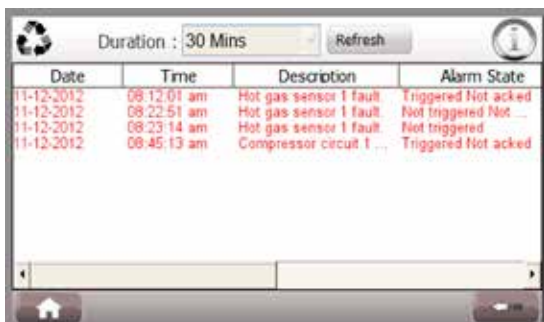

The software automatically stores the newest 100 fault messages. This menu allows resetting the fault log data stored. Possible alarms in Vsi ground source heat pump:

- Compressor 1 circuit 1 some motor protection gone off. Check motor protection F1, F2 or F3.
- Compressor 1 internal heat protection gone off. Wait 45 min.
- Low pressure pressostat of circuit 1 functioned. Accept presostat.
- High pressure pressostat of circuit 1 functioned. Accept presostat.
- Incorrect phase order. Change feed phase order.

- Temperature did not rise in pre set time. Resistance enabled.
- Not started information from compressor 1.
- Disturbance alarm from soft starter AK1 or AK4.
- Outside temperatur sensor fault.
- Hot gas sensor 1 fault.
- Low boiler sensor fault.
- Top boiler sensor fault.
- Heating circuit 1 sensor fault.
- Heating circuit 2 sensor fault.
- Heating circuit 3 sensor fault.
- Hot water temperature sensor fault
- Room temperature sensor fault.
- Alarm of liquid circuit
- External alarm
- Resistor functioned in full power system

5.4. Maintenance procedures

NOTE! Access to the maintenance menu is password-protected. Access to the maintenance menu is restricted to Lämpöässä installer training graduates and certified installers. Status data can be monitored through the maintenance menu. The monitoring options include digital inputs and outputs, analog inputs and outputs, and variables.

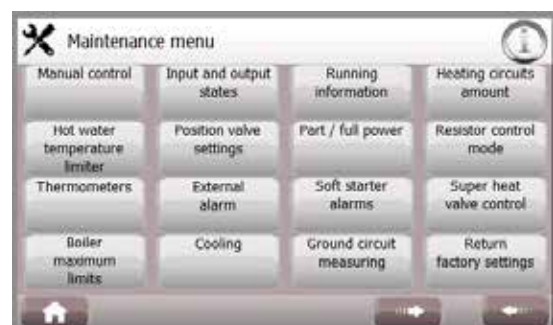

5.4.1. Manual control

This screen allows bypassing automatics and controlling compressors, pumps, and valves manually. Control has been divided between digital outputs and analog outputs.

Use the button in the bottom left corner to return to the home screen. Use the arrow button in the bottom right corner to return to previous screen. For instructions screen, press the 'i' button in the top right corner. In case of operation faults, an alarm button is displayed on the top bar.

100% GEOTHERMAL HEAT

MAINTENANCE MANUAL

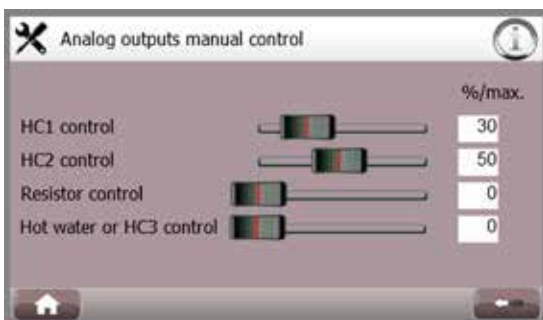

5.4.2. Input and output statuses

For the purpose and function of digital inputs and outputs, see equipment electrical diagrams.

Digital inputs

This screen allows checking digital input statuses.

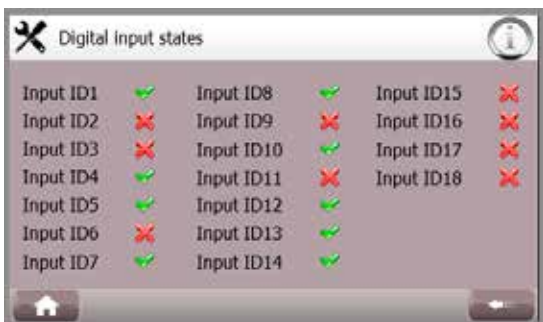

Digital Input (ID)

1 Compressor 1 Motor protection	10 Low pressure alarm circuit 1
2 Not in use	11 High pressure alarm circuit 1
3 Brine pump 1 Run indicator	12 Compressor 1 Run indicator
4 Not in use	13 Not in use
5 Not in use	14 Soft starter
6 Not in use	15 External Alarm
7 Compressor 1 internal alarm	16 Not in use
8 Not in use	17 Flow Sensor
9 Phase failure detector	18 Not in use

Digital outputs

This screen allows checking digital output statuses.

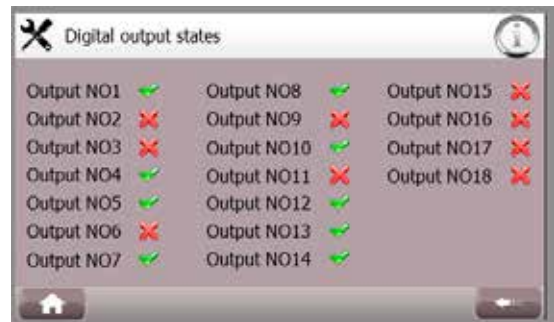

Digital Output (NO)

1 Brine circuit 1	10 Not in use
2 Not in use	11 Not in use
3 Alarm signal	12 Immersion heater 4
4 Compressor 1	13 Immersion heater 1
5 Condenser pump 1	14 Pump heating circuit 1
6 Magnetic valve 1	15 Pump heating circuit 2
7 Immersion heater 2	16 Pump heating circuit 3
8 Immersion heater 3	17 Not in use
9 Not in use	18 Pressure equalizing valve (only 1-phase devices)

Analog inputs

This screen allows checking analog input statuses.

Use the button in the bottom left corner to return to the home screen. Use the arrow button in the bottom right corner to return to previous screen. For instructions screen, press the 'i' button in the top right corner. In case of operation faults, an alarm button is displayed on the top bar.

MAINTENANCE MANUAL

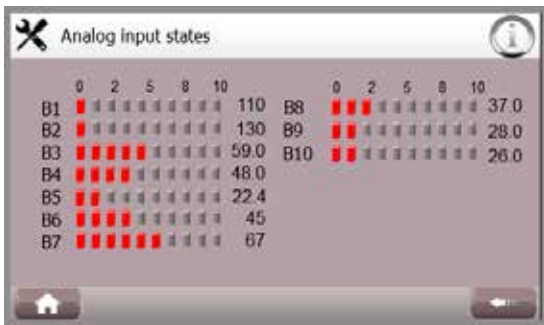

Analog Input (B)

1 Hot gas sensor 1	6 Circuit 1 outgoing temperature sensor
2 Not in use	7 Circuit 2 outgoing temperature sensor
3 Boiler top part temperature sensor	8 Circuit 3 outgoing temperature / Measurement of domestic hot water sensor
4 Boiler foot part temperature sensor	9 Inside temperature sensor
5 Outside temperature sensor	10 Brine temperature sensor

Analog outputs

This screen allows checking analog output statuses.

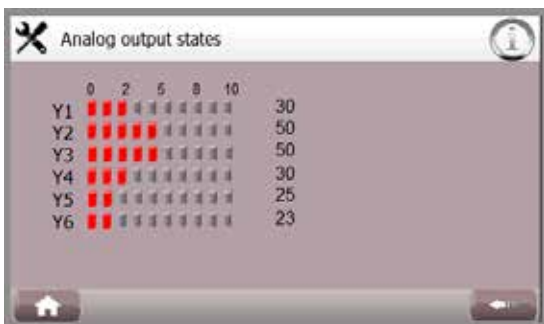

Analog Output (Y)

1 Heating circuit 1 regulation motor
2 Heating circuit 2 regulation motor
3 Analog immersion heater control 0-10V
4 Heating circuit 3 regulation motor/ Adjustment of domestic hot water
5 Speed regulation of brine pump
6 Superheat valve regulation

5.4.3. Running information

This screen shows compressor's current state.

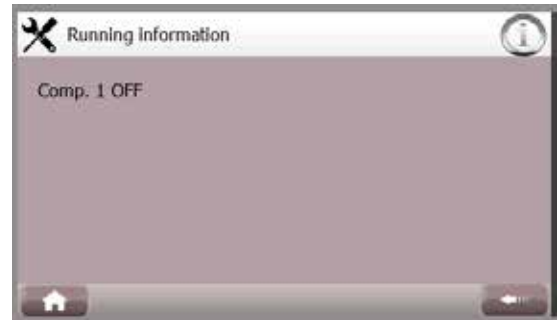

5.4.4. Heat distribution circuit quantity

There may be from 1 to 3 heat distribution circuits, of which circuits 2 and 3 are optional. If three heat distribution circuits are in use, the domestic water temperature limit function cannot be used at the same time.

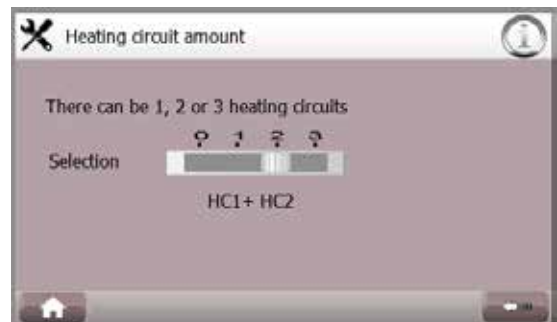

5.4.5. Domestic hot water temperature limit

This screen allows activation of the domestic hot water temperature limit and changing of the domestic hot water temperature sensor and the related position valve connection location. The default setting is that the temperature sensor is connected to analog input B8 and position valve to analog output Y4.

100% GEOTHERMAL HEAT

MAINTENANCE MANUAL

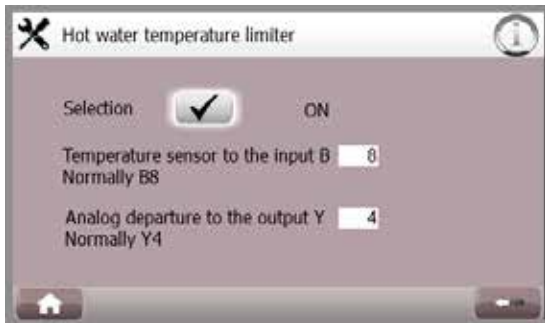

5.4.6. Positioning valve control

This screen allows determining the settings of position valves associated with heat distribution circuits and domestic hot water temperature limit. Each adjustable circuit has two setting screens.

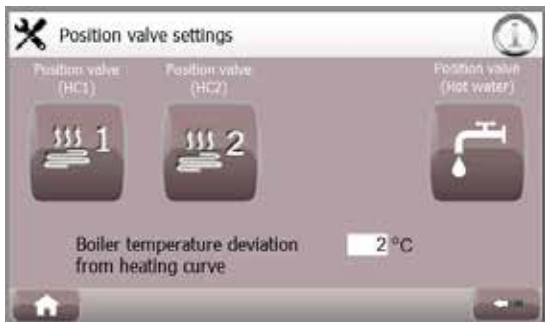

If the temperature at storage tank bottom part is lower than that of the heat distribution circuit, the storage tank temperature is automatically increased so as to meet the heat distribution circuit temperature with additional divergence value. Adjustment range 0...10 °C, factory setting 2 °C.

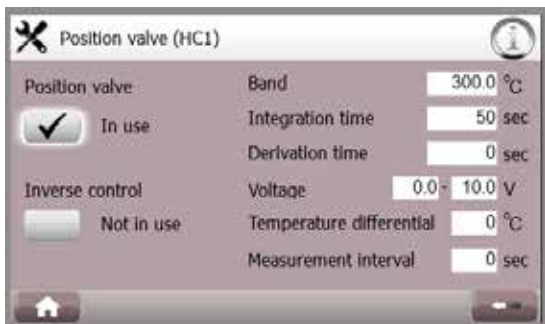

The following settings are possible for all circuits:

Setting	Description	Example
Reverse control (ON/OFF)	Reversing of position valve adjustment direction	In the OFF position, if voltage is 0 V, the regulator is in its extreme right position. In the ON position, if voltage is 0 V, the regulator is in its extreme left position.
Adjustment range (10...600°C)	The divergence from target temperature in which case the position valve is adjusted from one extreme position to another. Factory setting: 300 °C.*	If the adjustment range is 140 °C and the target temperature differs from the current temperature by 14 °C, the valve is adjusted to 10% of the maximum. If the temperature changes too quickly, the adjustment range is increased. If the temperature changes too slowly, the adjustment range is decreased.
Integration time (5...300 s)	Temperature divergence correction interval(s). Factory setting: 50 s.**	If integration time is 10 s, the valve position is changed once in every 10 s, if required.
Derivative time (0...10 s)	Temperature divergence reaction time. Factory setting: 0.	The longer the derivative time, the more the regulator position changes upon each adjustment. Consider that increase in derivative time may result in increased regulator fluctuation.
Voltage (0...10 V)	Position valve control voltage min and max values. Factory setting: 0.0-10.0 VAC.	This setting depends on the regulator used.
Temperature divergence (0...10 °C)	Allowed divergence from target temperature. Factory setting: 0 °C.	At value 5 °C, the regulator position is changed only after the difference between the actual temperature and target temperature exceeds 5 °C.
Frequency of measurements (0...30 s)	How often is the current temperature checked. Factory setting: 0.	At value 15 s, the current temperature is checked once in every 15 s. At value 0 the checking is continuous.

* Domestic water limit 30 °C ** Domestic water limit 40 s.

5.4.7. Part-power / Full power

The maintenance menu allows switching between full power (default setting) and part-power, in which case the equipment allows activation of the electric heating element or some other source of additional heat simultaneously with the compressor.



Use the button in the bottom left corner to return to the home screen. Use the arrow button in the bottom right corner to return to previous screen. For instructions screen, press the 'i' button in the top right corner. In case of operation faults, an alarm button is displayed on the top bar.

MAINTENANCE MANUAL

The heating time before heating element activation can be set under Additional heat settings in the Other set values screen.

5.4.8 Resistor controlling method

Resistors included to the geothermal heating system can be controlled either with analogic or digital signal. Here can be chosen which method to use.

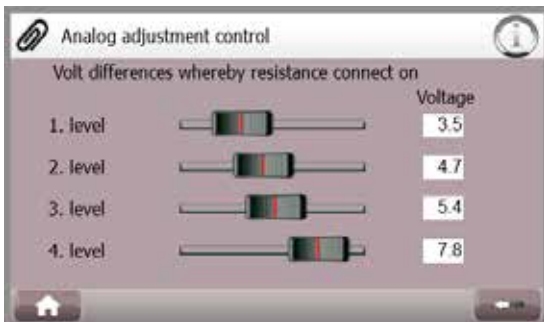

5.4.9. Temperature gauges

This screen allows choosing the temperature gauges used. By default, the outdoor temperature gauge is present. Indoor temperature gauge is optional.

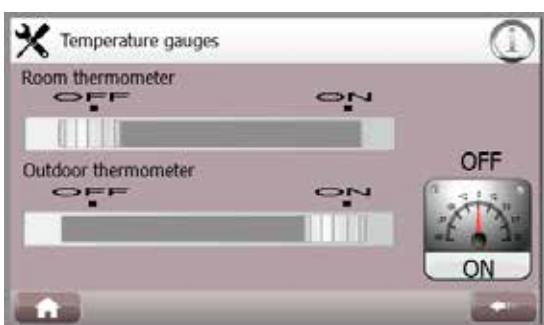

5.4.10. External alarm

On this page, if in use, external alarm settings are defined. Status is either info or serious. If the status is info external alarms doesn't affect to the heat pump operation. If the status is serious compressors are not starting. External alarm can be connected to digital inputs 17 or 18.



5.4.11. Soft starter alarms

The soft starter alarms can be activated at this page.



5.4.12. Super heat valve control

This menu is for adjusting superheat trim valve settings. Value in the menu indicates the setting point when compressor is running. Valve position between the compressor runs indicates valve settings point when compressor is not running. Frequency between the flushes is settled with rinse interval. Rinse is implemented on the first running period of the day when time indicated in the rinse interval is full. Valve type (NP/NC) is defined with the diversified controlling. Manual controlling settles the valve to the percentage indicated in the valve setting point.

Lämpöässä unit	Factory setting
Vsi 6-8	30%
Vsi 10-12	35%
Vsi 14	40%

Use the button in the bottom left corner to return to the home screen. Use the arrow button in the bottom right corner to return to previous screen. For instructions screen, press the 'i' button in the top right corner. In case of operation faults, an alarm button is displayed on the top bar.

100% GEOTHERMAL HEAT

MAINTENANCE MANUAL

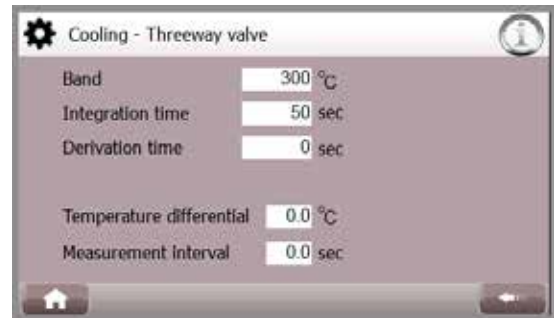
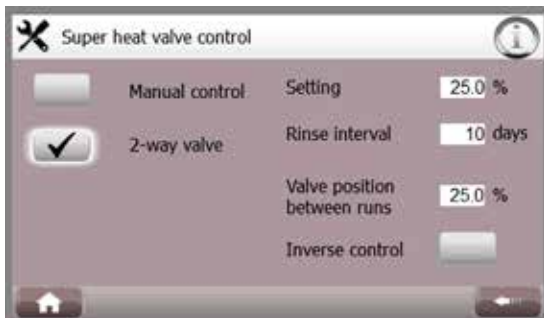

5.4.13. Boiler maximum limits

Maximum boiler limits are set on this page.



Jäähdytyksen käsikäyttö, joka on tarkoitettu toiminnon testausta varten. Käsikäytöllä muutetaan jäähdytysjärjestelmän toimitilaa, sekä lämpötilojen mittausrvoja manuaalisesti.

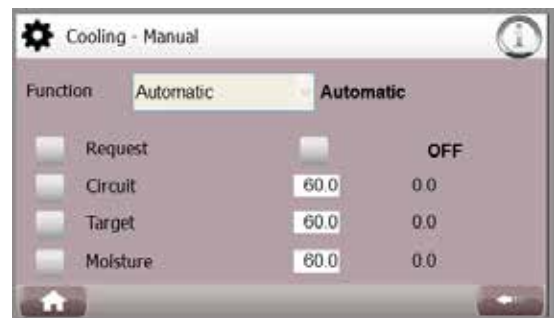

5.4.14. Cooling

Valittavissa on ohjaustavat: Huonelämpö, Ulkoinen ja Manuaalinen. Maapiirin nopeuden valinta jäähdytyksen ollessa käynnissä.

5.4.15. Factory settings

This screen allows cancelling all the changes made and restoring the (default) factory settings.

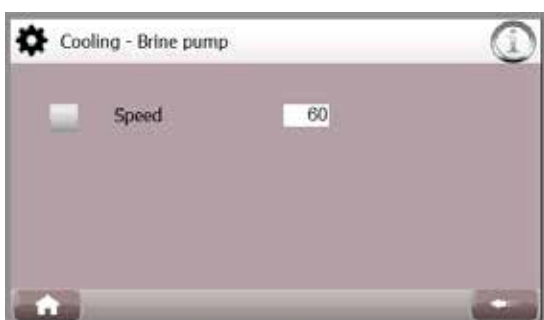

Vapaajäähdytyksessä kolmitieventtiin ohjauksen asetukset.

Use the button in the bottom left corner to return to the home screen. Use the arrow button in the bottom right corner to return to previous screen. For instructions screen, press the 'i' button in the top right corner. In case of operation faults, an alarm button is displayed on the top bar.

WARRANTY CONDITIONS

6. WARRANTY CONDITIONS

The manufacturer grants its products a two (2) year warranty from the commissioning date specified in the product's warranty certificate. During the warranty period, the manufacturer is responsible for that the product complies with its agreed characteristics and is free of manufacturing or design defects. The manufacturer's responsibility for the faults of its products involves only repair of a faulty product or replacement thereof with a faultless product, within a reasonable time and at the manufacturer's discretion. The manufacturer shall take care of product repairs through its own maintenance service or authorized maintenance centre. Faulty product components must be returned to the manufacturer.

The warranty does not cover any faults discovered in the products that have been caused through negligence of the purchaser or other user of the product, failure to comply with the product's instructions for use, maintenance or care, extreme voltage fluctuations (over ± 10 % of the nominal voltage), lightning, fire or other respective event. Transport damages are not covered by the warranty. Also, the warranty does not cover situations

caused by product installation to the place of use in contradiction with instructions for installation or use or otherwise incorrectly, or by product repair, modification or installation by some other party than the manufacturer or a maintenance company authorised by the manufacturer.

The warranty does not cover the adjustments or ground circuit and heat distribution circuit de-aeration procedures specified in the instructions for use. Furthermore, the warranty does not cover any faults caused by use of unauthorised and corrosive fluids in the ground circuit piping. The manufacturer only grants the aforementioned warranty and this warranty is the only warranty granted by the manufacturer to its products. The aforementioned warranty does not concern any additional equipment or accessories installed afterwards and subject to their own warranty.

An additional warranty condition associated with Lämpöässä geothermal heat pump is compressor preheating prior to starting thereof for the first time (see 4.4. Commissioning).

TECHNICAL SPECIFICATIONS

7. TECHNICAL SPECIFICATIONS

LÄMPÖÄSSÄ		Vsi 6	Vsi 8	Vsi 8 1x230V	Vsi 10	Vsi 12	Vsi 12 1x230V	Vsi 14
Width	mm	595	595	595	595	595	595	595
Depth	mm	680	680	680	680	680	680	680
Height	mm	1830	1830	1830	1830	1830	1830	1830
Weight	kg	330	332	332	334	338	338	340
Heat pump type		Brine-to-water	Brine-to-water	Brine-to-water	Brine-to-water	Brine-to-water	Brine-to-water	Brine-to-water
Compressor type		Scroll	Scroll	Scroll	Scroll	Scroll	Scroll	Scroll
Refrigerant		R407C	R407C	R407C	R407C	R407C	R407C	R407C
Refrigerant volume	g	1400	1400	1400	1800	1800	1800	1800
Compressor oil		POE	POE	POE	POE	POE	POE	POE
Storage tank volume	l	230	230	230	230	230	230	230
Maximum pressure of storage tank	bar	1,5	1,5	1,5	1,5	1,5	1,5	1,5
Heating regulator		ÄssäControl	ÄssäControl	ÄssäControl	ÄssäControl	ÄssäControl	ÄssäControl	ÄssäControl
Evaporator material		Stainless Steel	Stainless Steel	Stainless Steel	Stainless Steel	Stainless Steel	Stainless Steel	Stainless Steel
Brine volume in evaporator		2,1	2,1	2,1	3,2	3,2	3,2	3,2
Condenser material		Stainless Steel	Stainless Steel	Stainless Steel	Stainless Steel	Stainless Steel	Stainless Steel	Stainless Steel
Water volume in condenser		1,8	1,8	1,8	2,7	2,7	2,7	2,7
Factory setting of condenser pump		Constant curve 1	Constant curve 1	Constant curve 1	Constant curve 2	Constant curve 2	Constant curve 2	Constant curve 3
Factory setting of superheat circuit	%	30	30	30	35	35	35	40
Sound power level ⁽¹⁾	dB	42	42	42	43	41	42	42
OPERATION LIMITS:								
Temperature limits (brine/water)	°C	-10/60, 15/30	-10/60, 15/30	-10/60, 15/30	-10/60, 15/30	-10/60, 15/30	-10/60, 15/30	-10/60, 15/30
Pressure limit (refrigerant)	bar	1,5/29	1,5/29	1,5/29	1,5/29	1,5/29	1,5/29	1,5/29
PERFORMANCE DATA:								
Heating power at temperature 35°C ⁽²⁾	kW	6,14	8,44	8,41	10,44	11,84	12,314	15,04
Heating power at temperature 55°C ⁽²⁾	kW	5,50	7,75	7,77	9,82	10,83	11,20	14,02
Cooling power at temperature 35°C ⁽²⁾	kW	5,09	6,91	6,95	8,49	10,04	10,25	12,18
Cooling power at temperature 55°C ⁽²⁾	kW	4,10	5,62	5,62	6,88	8,25	8,19	9,90
Input power at temperature 35°C ⁽²⁾	kW	1,23	1,70	1,76	2,15	2,48	2,53	3,17
Input power at temperature 55°C ⁽²⁾	kW	1,72	2,34	2,43	3,10	3,44	3,60	4,31
COP at temperature 35 ⁽²⁾		5,00	4,69	4,78	4,84	4,77	4,79	4,75
COP at temperature 55 ⁽²⁾		3,19	3,30	3,19	3,17	3,14	3,11	3,25
SCOP 35°C / energy efficiency class 35°C ⁽³⁾		5,14 / A+++	5,24 / A+++	4,94 / A+++	5,13 / A+++	4,89 / A+++	5,10 / A+++	5,08 / A+++
SCOP 55°C / energy efficiency class 55°C ⁽³⁾		3,74 / A++	3,88 / A+++	3,77 / A+++	3,83 / A+++	3,75 / A++	3,80 / A+++	3,89 / A+++
Domestic hot water heating energy efficiency / energy efficiency class ⁽³⁾		3,32 / A*	3,37 / A*	3,15 / A*	3,22 / A*	3,78 / A*	3,33 / A*	3,31 / A*
Domestic hot water load profile ⁽³⁾		XL	XL	XL	XL	XL	XL	XL
Energy efficiency class at 35°C (space heating / domestic hot water), package ⁽⁴⁾		A+++ / A+	A+++ / A+	A+++ / A+	A+++ / A+	A+++ / A+	A+++ / A+	A+++ / A+
Energy efficiency class at 55°C (space heating / domestic hot water), package ⁽⁴⁾		A+++ / A+	A+++ / A+	A+++ / A+	A+++ / A+	A+++ / A+	A+++ / A+	A+++ / A+

TECHNICAL SPECIFICATIONS

ELECTRICS:		Vsi 6	Vsi 8	Vsi 8 1x230V	Vsi 10	Vsi 12	Vsi 12 1x230V	Vsi 14
Power supply		400V 3N~ 50Hz	400V 3N~ 50Hz	230V 1N~ 50Hz	400V 3N~ 50Hz	400V 3N~ 50Hz	230V 1N~ 50Hz	400V 3N~ 50Hz
Starting current	A	15	17	35	23	32	48	35
Running current (35°C / 55°C) ¹²	A	2,68 / 3,25	3,28 / 4,18	9,54 / 12,31	4,33 / 5,52	4,92 / 6,41	12,96/17,82	6,81 / 8,10
Fuse size (bivalent model)	A	3 x 10 (16)	3 x 16 (20)	25	3 x 16 (20)	3 x 16 (20)	32	3 x 16 (20)
Immersion heater as a backup heating	kW	6	6	6	6	6	6	6
Supply cable size (bivalent model) ¹⁵	mm ²	5 x 2,5 (5x6)	5 x 2,5 (5x6)	3 x 6	5 x 2,5 (5x6)	5 x 2,5 (5x6)	3 x 6	5 x 2,5 (5x6)
Soft starter		Yes	Yes	Yes	Yes	Yes	Yes	Yes
Current control		Accessory	Accessory	No	Accessory	Accessory	No	Accessory
Compressor motor circuit breaker setting	A	6	6	18,5	7	9	22	10
HEAT COLLECTION CIRCUIT(S):								
Energy class of brine pump		A (inverter)	A (inverter)	A (inverter)	A (inverter)	A (inverter)	A (inverter)	A (inverter)
Input power of brine pump	W	5-89	5-89	5-89	10-170	10-170	10-170	10-170
Factory setting of brine pump	%	90	90	90	90	90	90	90
Ground loop maximum length, 1 ground loop ¹⁶	Borehole, PEH, PN6	m	900	500	500	550	450	-
	Horizontal pipe, PEM, PN10	m	800	350	350	450	350	-
Ground loop maximum length, 2 ground loops ¹⁶	Borehole, PEH, PN6	m	-	1350	1350	950	1400	1600
	Horizontal pipe, PEM, PN10	m	-	1200	1200	800	1200	1250
Nominal flow	ΔT=3K (ISO 14511)	l/s	0,47	0,64	0,63	0,79	0,89	0,91
Maximum external pressure drop		kPa	66	52	52	96	85	82
Nominal flow	ΔT=4K	l/s	0,36	0,51	0,47	0,64	0,70	0,68
Maximum external pressure drop		kPa	68	57	58	104	100	82
HEAT DISTRIBUTION CIRCUIT:								
Energy class of HC pump		A (inverter)	A (inverter)	A (inverter)	A (inverter)	A (inverter)	A (inverter)	A (inverter)
Input power of HC pump	W	5-53	5-53	5-53	5-53	5-53	5-53	5-53
Factory setting of condenser pump		Proportional pressure 3						
Nominal flow	ΔT=5K	l/s	0,29	0,40	0,40	0,50	0,56	0,58
Maximum external pressure drop	Floor heating	kPa	69	55	55	42	37	31
Nominal flow	ΔT=10K	l/s	0,13	0,18	0,19	0,23	0,26	0,27
Maximum external pressure drop	Radiator heating	kPa	70	71	71	71	71	66

*Meets the energy efficiency class A+++ requirements. Meets the domestic hot water energy efficiency class A+ requirements.

¹¹ Tested according to ISO 3744/2010 at standard point B0/W55.

¹² Tested according to ISO 14511/2013.

¹³ Tested according to EU 811/2013 at colder climate conditions.

¹⁴ Package means the combination of heat pump and heating regulator (EU 811/2013).

¹⁵ If conditions are requiring long cable work it is recommended to use 5x6 mm² cable.

¹⁶ Calculated length according to nominal flow at ΔT=4K. Actual pressure drop is determined case by case.

8. ENERGY LABEL

9. ELECTRICITY SCHEMES

10. HVAC SCHEMES



ENERG
енергия · ενεργεια

Y IJA
IE IA

LÄMPÖÄSSÄ

Vsi 6

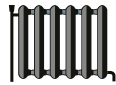

A++

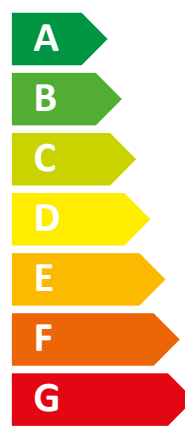

A

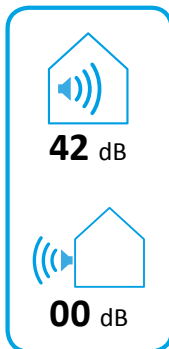

2015

811/2013



ENERG

енергия · ενεργεια

Y





IJA

IE

IA

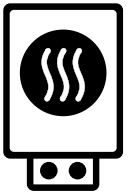
LÄMPÖÄSSÄ

Vsi 6



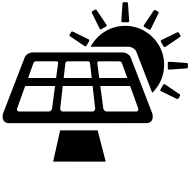







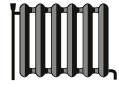

+ 

+ 

+ 

+ 

Product description

Name or trademark	Lämpöässä		
Model	Vsi 6		
Seasonal space heating application	Average		
Water heating load profile	XL		
Seasonal space heating energy efficiency class	A++		
Water heating energy efficiency class	A		
Rated heat output under average climate conditions	6		kW
Annual electricity consumption under average climate conditions	3041		kWh
Annual electricity consumption for water heating	1417		kWh
Seasonal space heating energy efficiency under average climate conditions	149		%
Water heating energy efficiency under average climate conditions	130		%
Sound power level indoors	42		dB

Rated heat output under colder and warmer climate conditions	Colder	6	kW
	Warmer	6	kW
Annual electricity consumption for space heating under colder and warmer climate conditions	Colder	3539	kWh/a
	Warmer	1994	kWh/a
Annual electricity consumption for water heating under colder and warmer climate conditions	Colder	1417	kWh/a
	Warmer	1417	kWh/a
Energy efficiency for space heating under colder and warmer climate conditions	Colder	153	%
	Warmer	147	%
Energy efficiency for water heating under colder and warmer climate conditions	Colder	130	%
	Warmer	130	%

Package information

Controller class	III		
Controller contribution to efficiency	1,5		%
Seasonal space heating energy efficiency class of package	A+++		
Seasonal space heating energy efficiency of package in average climate conditions	151		%
Seasonal space heating energy efficiency of package in colder climate conditions	155		%
Seasonal space heating energy efficiency of package in warmer climate conditions	149		%

Function	Heating	Average		
		Warmer		
		Colder		
	Capacity control	Fixed		

Design load	Heating	Average	Pdesignh	5,5	kW
		Warmer	Pdesignh	5,5	kW
		Colder	Pdesignh	5,5	kW

Seasonal efficiency	Heating	Average	SCOP/A	149	%
		Warmer	SCOP/W	147	%
		Colder	SCOP/C	153	%



Declared capacity for heating at indoor conditions 20°C and outdoor temperature Tj	Heating	Average	Tj = -7 °C	5,6	kW	3,35	COPd		
			Tj = 2 °C	5,7	kW	3,86	COPd		
			Tj = 7 °C	5,9	kW	4,23	COPd		
			Tj = 12 °C	6,0	kW	4,44	COPd		
			Tj = bivalent temperaturea	5,5	kW	3,19	COPd		
			Tj = operation limit	5,5	kW	3,19	COPd		
		Warmer	Tj = 2 °C	5,5	kW	3,19	COPd		
			Tj = 7 °C	5,8	kW	3,67	COPd		
			Tj = 12 °C	5,9	kW	4,31	COPd		
			Tj = bivalent temperaturea	5,5	kW	3,19	COPd		
			Tj = operation limit	5,5	kW	3,19	COPd		
		Colder	Tj = -7 °C	5,7	kW	3,74	COPd		
			Tj = 2 °C	5,8	kW	4,14	COPd		
			Tj = 7 °C	6,0	kW	4,47	COPd		
			Tj = 12 °C	6,1	kW	4,43	COPd		
			Tj = bivalent temperaturea	5,5	kW	3,19	COPd		
			Tj = operation limit	5,5	kW	3,19	COPd		
		Degradation coefficient when Tj = -7 °C				Cdh	0,99		

Bivalent temperatures	Heating	Average	Tbivalent	-10	°C
		Warmer	Tbivalent	-22	°C
		Colder	Tbivalent	2	°C

Operation limit temperatures	Heating	Average	TOL	-10	°C
		Warmer	TOL	-22	°C
		Colder	TOL	2	°C

Seasonal electricity consumption	Heating	Average	QHE/A	3041	kWh/a
		Warmer	QHE/W	3539	kWh/a
		Colder	QHE/C	1994	kWh/a

Modes other than active mode	Off mode	P _{OFF}	0,017	kWh
	Standby mode	P _{SB}	0,017	kWh
	Thermostat off mode	P _{TO}	0,017	kWh
	Crancckaseheater mode	P _{CK}	0,017	kWh

Heating up time	2:57	h:min
Heating up energy input	4,80	kWh
Standby power input	0,121	kW
Class of the measured tapping cycle and the determined electrical energy consumption W _{EL-TC} for each measured cycle	XL	
	6,44	kWh
COP _{DHW} and energy class of used tapping cycle	3,24	A+
Reference hot water temperature	49	°C
Maximum quantity od usable hot water	256	l
Temperature operating range: minimal and maximal heaetsource temperature, minimal start and maximal mean temperature domestic hot water	-10/15	°C
	20	
	53	

Contact details for obtaining more information	Name manufacturer	Suomen Lämpöpumpputekniikka Oy
	Address	Unikontie 2, 62100 LAPUA, FINLAND





ENERG
енергия · ενεργεια



LÄMPÖÄSSÄ

Vsi 8

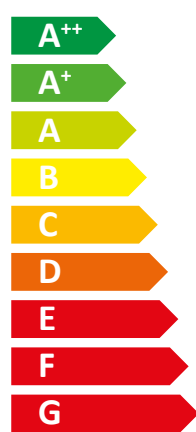
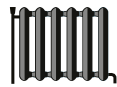

A⁺⁺

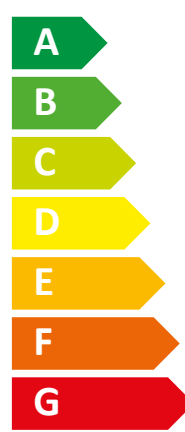

A

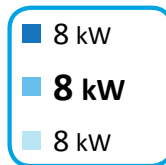
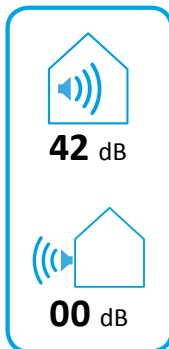

2015

811/2013





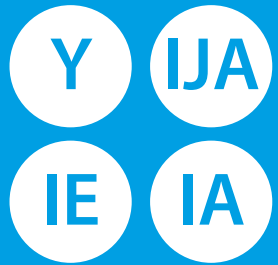

ENERG

енергия · ενέργεια



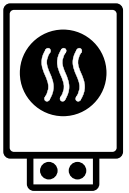

LÄMPÖÄSSÄ

Vsi 8

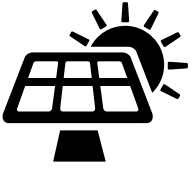









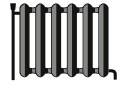

+ 

+ 

+ 

+ 

Product description

Name or trademark	Lämpöässä		
Model	Vsi 8		
Seasonal space heating application	Average		
Water heating load profile	XL		
Seasonal space heating energy efficiency class	A++		
Water heating energy efficiency class	A		
Rated heat output under average climate conditions	8		kW
Annual electricity consumption under average climate conditions	4116		kWh
Annual electricity consumption for water heating	1362		kWh
Seasonal space heating energy efficiency under average climate conditions	156		%
Water heating energy efficiency under average climate conditions	135		%
Sound power level indoors	42		dB

Rated heat output under colder and warmer climate conditions	Colder	8	kW
	Warmer	8	kW
Annual electricity consumption for space heating under colder and warmer climate conditions	Colder	4786	kWh/a
	Warmer	2695	kWh/a
Annual electricity consumption for water heating under colder and warmer climate conditions	Colder	1362	kWh/a
	Warmer	1362	kWh/a
Energy efficiency for space heating under colder and warmer climate conditions	Colder	160	%
	Warmer	154	%
Energy efficiency for water heating under colder and warmer climate conditions	Colder	135	%
	Warmer	135	%

Package information

Controller class	III		
Controller contribution to efficiency	1,5		%
Seasonal space heating energy efficiency class of package	A+++		
Seasonal space heating energy efficiency of package in average climate conditions	151		%
Seasonal space heating energy efficiency of package in colder climate conditions	155		%
Seasonal space heating energy efficiency of package in warmer climate conditions	149		%

Function	Heating	Average		
		Warmer		
		Colder		
	Capacity control	Fixed		

Design load	Heating	Average	Pdesignh	7,75	kW
		Warmer	Pdesignh	7,75	kW
		Colder	Pdesignh	7,75	kW

Seasonal efficiency	Heating	Average	SCOP/A	156	%
		Warmer	SCOP/W	154	%
		Colder	SCOP/C	160	%



Declared capacity for heating at indoor conditions 20°C and outdoor temperature Tj	Heating	Average	Tj = -7 °C	7,8	kW	3,42	COPd	
			Tj = 2 °C	8,0	kW	3,97	COPd	
			Tj = 7 °C	8,1	kW	4,33	COPd	
			Tj = 12 °C	8,3	kW	4,61	COPd	
			Tj = bivalent temperaturea	7,8	kW	3,30	COPd	
			Tj = operation limit	7,8	kW	3,30	COPd	
		Warmer	Tj = 2 °C	7,8	kW	3,30	COPd	
			Tj = 7 °C	8,0	kW	3,74	COPd	
			Tj = 12 °C	8,2	kW	4,43	COPd	
			Tj = bivalent temperaturea	7,8	kW	3,30	COPd	
			Tj = operation limit	7,8	kW	3,30	COPd	
		Colder	Tj = -7 °C	8,0	kW	3,83	COPd	
			Tj = 2 °C	8,2	kW	4,27	COPd	
			Tj = 7 °C	8,3	kW	4,60	COPd	
			Tj = 12 °C	8,5	kW	4,66	COPd	
			Tj = bivalent temperaturea	7,8	kW	3,30	COPd	
			Tj = operation limit	7,8	kW	3,30	COPd	
		Degradation coefficient when Tj = -7 °C				Cdh	0,99	

Bivalent temperatures	Heating	Average	Tbivalent	-10	°C
		Warmer	Tbivalent	-22	°C
		Colder	Tbivalent	2	°C

Operation limit temperatures	Heating	Average	TOL	-10	°C
		Warmer	TOL	-22	°C
		Colder	TOL	2	°C

Seasonal electricity consumption	Heating	Average	QHE/A	4116	kWh/a
		Warmer	QHE/W	4786	kWh/a
		Colder	QHE/C	2695	kWh/a

Modes other than active mode	Off mode	P _{OFF}	0,017	kWh
	Standby mode	P _{SB}	0,017	kWh
	Thermostat off mode	P _{TO}	0,017	kWh
	Crackcaseheater mode	P _{CK}	0,017	kWh

Heating up time	2:05	h:min
Heating up energy input	4,62	kWh
Standby power input	0,118	kW
Class of the measured tapping cycle and the determined electrical energy consumption W _{EL-TC} for each measured cycle	XL	
	6,19	kWh
COP _{DHW} and energy class of used tapping cycle	3,37	A+
Reference hot water temperature	49	°C
Maximum quantity of usable hot water	263	l
Temperature operating range: minimal and maximal heatsource temperature, minimal start and maximal mean temperature domestic hot water	-10/15	°C
	20	
	53	

Contact details for obtaining more information	Name manufacturer	Suomen Lämpöpumpputekniikka Oy
	Address	Unikontie 2, 62100 LAPUA, FINLAND





ENERG
енергия · ενεργεια

Y IJA
IE IA

LÄMPÖÄSSÄ

Vsi 8 1x230V

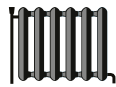

A++

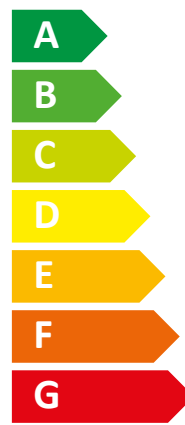

A

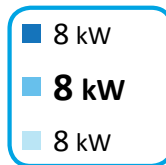
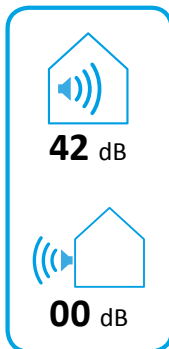

2015

811/2013



ENERG

енергия · ενεργεια

Y





IJA

IE

IA

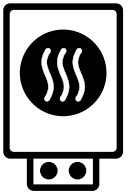
LÄMPÖÄSSÄ

Vsi 8 1x230 V



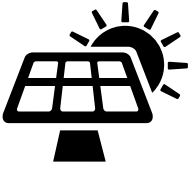







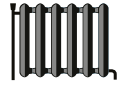

+ 

+ 

+ 

+ 

Product description

Name or trademark	Lämpöässä		
Model	Vsi 8 1x230V		
Seasonal space heating application	Average		
Water heating load profile	XL		
Seasonal space heating energy efficiency class	A++		
Water heating energy efficiency class	A		
Rated heat output under average climate conditions	8		kW
Annual electricity consumption under average climate conditions	4248		kWh
Annual electricity consumption for water heating	1457		kWh
Seasonal space heating energy efficiency under average climate conditions	151		%
Water heating energy efficiency under average climate conditions	126		%
Sound power level indoors	42		dB

Rated heat output under colder and warmer climate conditions	Colder	8	kW
	Warmer	8	kW
Annual electricity consumption for space heating under colder and warmer climate conditions	Colder	4965	kWh/a
	Warmer	2792	kWh/a
Annual electricity consumption for water heating under colder and warmer climate conditions	Colder	1457	kWh/a
	Warmer	1457	kWh/a
Energy efficiency for space heating under colder and warmer climate conditions	Colder	154	%
	Warmer	149	%
Energy efficiency for water heating under colder and warmer climate conditions	Colder	126	%
	Warmer	126	%

Package information

Controller class	III		
Controller contribution to efficiency	1,5		%
Seasonal space heating energy efficiency class of package	A+++		
Seasonal space heating energy efficiency of package in average climate conditions	153		%
Seasonal space heating energy efficiency of package in colder climate conditions	156		%
Seasonal space heating energy efficiency of package in warmer climate conditions	150		%

Function	Heating	Average		
		Warmer		
		Colder		
	Capacity control	Fixed		

Design load	Heating	Average	Pdesignh	7,8	kW
		Warmer	Pdesignh	7,8	kW
		Colder	Pdesignh	7,8	kW

Seasonal efficiency	Heating	Average	SCOP/A	151	%
		Warmer	SCOP/W	149	%
		Colder	SCOP/C	154	%



Declared capacity for heating at indoor conditions 20°C and outdoor temperature Tj	Heating	Average	Tj = -7 °C	7,8	kW	3,34	COPd		
			Tj = 2 °C	8,0	kW	3,86	COPd		
			Tj = 7 °C	8,1	kW	4,18	COPd		
			Tj = 12 °C	8,3	kW	4,49	COPd		
			Tj = bivalent temperaturea	7,8	kW	3,19	COPd		
			Tj = operation limit	7,8	kW	3,19	COPd		
		Warmer	Tj = 2 °C	7,8	kW	3,19	COPd		
			Tj = 7 °C	8,0	kW	3,59	COPd		
			Tj = 12 °C	8,2	kW	4,29	COPd		
			Tj = bivalent temperaturea	7,8	kW	3,19	COPd		
			Tj = operation limit	7,8	kW	3,19	COPd		
		Colder	Tj = -7 °C	8,0	kW	3,72	COPd		
			Tj = 2 °C	8,2	kW	4,12	COPd		
			Tj = 7 °C	8,3	kW	4,41	COPd		
			Tj = 12 °C	8,5	kW	4,49	COPd		
			Tj = bivalent temperaturea	7,8	kW	3,19	COPd		
			Tj = operation limit	7,8	kW	3,19	COPd		
		Degradation coefficient when Tj = -7 °C				Cdh	1,0		

Bivalent temperatures	Heating	Average	Tbivalent	-10	°C
		Warmer	Tbivalent	-22	°C
		Colder	Tbivalent	2	°C

Operation limit temperatures	Heating	Average	TOL	-10	°C
		Warmer	TOL	-22	°C
		Colder	TOL	2	°C

Seasonal electricity consumption	Heating	Average	QHE/A	4248	kWh/a
		Warmer	QHE/W	4965	kWh/a
		Colder	QHE/C	2792	kWh/a

Modes other than active mode	Off mode	P _{OFF}	0,017	kWh
	Standby mode	P _{SB}	0,017	kWh
	Thermostat off mode	P _{TO}	0,017	kWh
	Crackcaseheater mode	P _{CK}	0,017	kWh

Heating up time	2:04	h:min
Heating up energy input	4,94	kWh
Standby power input	0,126	kW
Class of the measured tapping cycle and the determined electrical energy consumption W _{EL-TC} for each measured cycle	XL	
	6,62	kWh
COP _{DHW} and energy class of used tapping cycle	3,15	A+
Reference hot water temperature	49	°C
Maximum quantity of usable hot water	263	l
Temperature operating range: minimal and maximal heatsource temperature, minimal start and maximal mean temperature domestic hot water	-10/15	°C
	20	
	53	

Contact details for obtaining more information	Name manufacturer	Suomen Lämpöpumpputekniikka Oy
	Address	Unikontie 2, 62100 LAPUA, FINLAND





ENERG
енергия · ενεργεια

Y IJA
IE IA

LÄMPÖÄSSÄ

Vsi 10

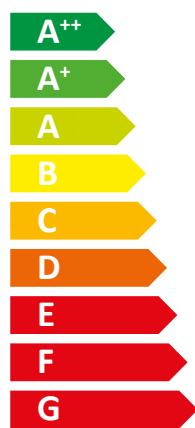
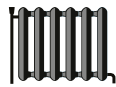

A⁺⁺

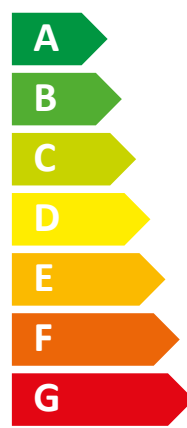

A

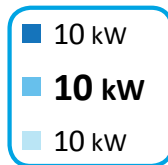
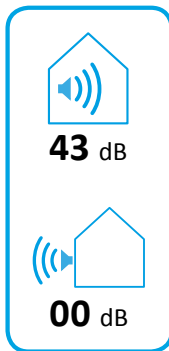



ENERG

енергия · ενεργεια

Y





IJA

IE

IA

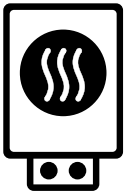
LÄMPÖÄSSÄ

Vsi 10



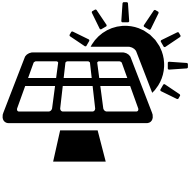







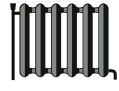

+ 

+ 

+ 

+ 

Product description

Name or trademark	Lämpöässä		
Model	Vsi 10		
Seasonal space heating application	Average		
Water heating load profile	XL		
Seasonal space heating energy efficiency class	A++		
Water heating energy efficiency class	A		
Rated heat output under average climate conditions	10		kW
Annual electricity consumption under average climate conditions	5296		kWh
Annual electricity consumption for water heating	1424		kWh
Seasonal space heating energy efficiency under average climate conditions	153		%
Water heating energy efficiency under average climate conditions	129		%
Sound power level indoors	43		dB

Rated heat output under colder and warmer climate conditions	Colder	10	kW
	Warmer	10	kW
Annual electricity consumption for space heating under colder and warmer climate conditions	Colder	6181	kWh/a
	Warmer	3418	kWh/a
Annual electricity consumption for water heating under colder and warmer climate conditions	Colder	1424	kWh/a
	Warmer	1424	kWh/a
Energy efficiency for space heating under colder and warmer climate conditions	Colder	157	%
	Warmer	154	%
Energy efficiency for water heating under colder and warmer climate conditions	Colder	129	%
	Warmer	129	%

Package information

Controller class	III		
Controller contribution to efficiency	1,5		%
Seasonal space heating energy efficiency class of package	A+++		
Seasonal space heating energy efficiency of package in average climate conditions	153		%
Seasonal space heating energy efficiency of package in colder climate conditions	154		%
Seasonal space heating energy efficiency of package in warmer climate conditions	157		%

Function	Heating	Average		
		Warmer		
		Colder		
	Capacity control	Fixed		

Design load	Heating	Average	Pdesignh	9,82	kW
		Warmer	Pdesignh	9,82	kW
		Colder	Pdesignh	9,82	kW

Seasonal efficiency	Heating	Average	SCOP/A	153	%
		Warmer	SCOP/W	154	%
		Colder	SCOP/C	157	%



Declared capacity for heating at indoor conditions 20°C and outdoor temperature Tj	Heating	Average	Tj = -7 °C	9,9	kW	3,32	COPd		
			Tj = 2 °C	10,0	kW	3,88	COPd		
			Tj = 7 °C	10,2	kW	4,28	COPd		
			Tj = 12 °C	10,4	kW	4,64	COPd		
			Tj = bivalent temperaturea	9,8	kW	3,10	COPd		
			Tj = operation limit	9,8	kW	3,10	COPd		
		Warmer	Tj = 2 °C	9,8	kW	3,10	COPd		
			Tj = 7 °C	10,0	kW	3,68	COPd		
			Tj = 12 °C	10,3	kW	4,42	COPd		
			Tj = bivalent temperaturea	9,8	kW	3,10	COPd		
			Tj = operation limit	9,8	kW	3,10	COPd		
		Colder	Tj = -7 °C	10,1	kW	3,72	COPd		
			Tj = 2 °C	10,2	kW	4,18	COPd		
			Tj = 7 °C	10,4	kW	4,57	COPd		
			Tj = 12 °C	10,7	kW	4,72	COPd		
			Tj = bivalent temperaturea	9,8	kW	3,10	COPd		
			Tj = operation limit	9,8	kW	3,10	COPd		
		Degradation coefficient when Tj = -7 °C				Cdh	0,99		

Bivalent temperatures	Heating	Average	Tbivalent	-10	°C
		Warmer	Tbivalent	-22	°C
		Colder	Tbivalent	2	°C

Operation limit temperatures	Heating	Average	TOL	-10	°C
		Warmer	TOL	-22	°C
		Colder	TOL	2	°C

Seasonal electricity consumption	Heating	Average	QHE/A	5296	kWh/a
		Warmer	QHE/W	6181	kWh/a
		Colder	QHE/C	3418	kWh/a

Modes other than active mode	Off mode	P _{OFF}	0,017	kWh
	Standby mode	P _{SB}	0,017	kWh
	Thermostat off mode	P _{TO}	0,017	kWh
	Crackcaseheater mode	P _{CK}	0,017	kWh

Heating up time	1:39	h:min
Heating up energy input	4,83	kWh
Standby power input	0,124	kW
Class of the measured tapping cycle and the determined electrical energy consumption W _{EL-TC} for each measured cycle	XL	
	6,47	kWh
COP _{DHW} and energy class of used tapping cycle	3,22	A+
Reference hot water temperature	49	°C
Maximum quantity of usable hot water	269	l
Temperature operating range: minimal and maximal heatsource temperature, minimal start and maximal mean temperature domestic hot water	-10/15	°C
	20	
	53	

Contact details for obtaining more information	Name manufacturer	Suomen Lämpöpumpputekniikka Oy
	Address	Unikontie 2, 62100 LAPUA, FINLAND





ENERG
енергия · ενεργεια



LÄMPÖÄSSÄ

Vsi 12

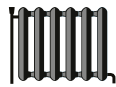

A⁺⁺

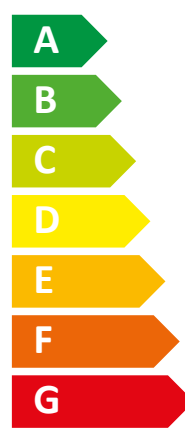

A

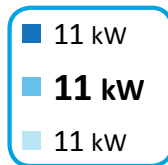
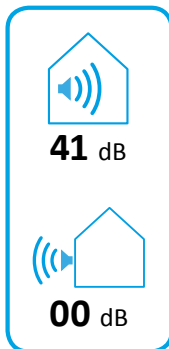





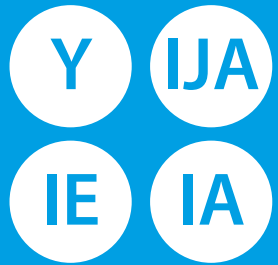

ENERG
енергия · ενεργεια



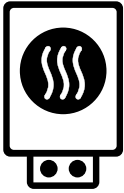

LÄMPÖÄSSÄ



Vsi 12

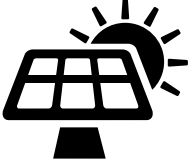

+









+

+

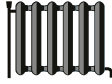
+

Product description

Name or trademark	Lämpöässä		
Model	Vsi 12		
Seasonal space heating application	Average		
Water heating load profile	XL		
Seasonal space heating energy efficiency class	A++		
Water heating energy efficiency class	A		
Rated heat output under average climate conditions	11		kW
Annual electricity consumption under average climate conditions	5972		kWh
Annual electricity consumption for water heating	1214		kWh
Seasonal space heating energy efficiency under average climate conditions	150		%
Water heating energy efficiency under average climate conditions	151		%
Sound power level indoors	41		dB

Rated heat output under colder and warmer climate conditions	Colder	11	kW
	Warmer	11	kW
Annual electricity consumption for space heating under colder and warmer climate conditions	Colder	6922	kWh/a
	Warmer	3907	kWh/a
Annual electricity consumption for water heating under colder and warmer climate conditions	Colder	1214	kWh/a
	Warmer	1214	kWh/a
Energy efficiency for space heating under colder and warmer climate conditions	Colder	154	%
	Warmer	148	%
Energy efficiency for water heating under colder and warmer climate conditions	Colder	151	%
	Warmer	151	%

Package information

Controller class	III		
Controller contribution to efficiency	1,5		%
Seasonal space heating energy efficiency class of package	A+++		
Seasonal space heating energy efficiency of package in average climate conditions	151		%
Seasonal space heating energy efficiency of package in colder climate conditions	156		%
Seasonal space heating energy efficiency of package in warmer climate conditions	150		%

Function	Heating	Average		
		Warmer		
		Colder		
	Capacity control	Fixed		

Design load	Heating	Average	Pdesignh	10,83	kW
		Warmer	Pdesignh	10,83	kW
		Colder	Pdesignh	10,83	kW

Seasonal efficiency	Heating	Average	SCOP/A	150	%
		Warmer	SCOP/W	148	%
		Colder	SCOP/C	154	%



Declared capacity for heating at indoor conditions 20°C and outdoor temperature Tj	Heating	Average	Tj = -7 °C	10,9	kW	3,32	COPd	
			Tj = 2 °C	11,1	kW	3,78	COPd	
			Tj = 7 °C	11,3	kW	4,13	COPd	
			Tj = 12 °C	11,4	kW	4,42	COPd	
			Tj = bivalent temperaturea	10,8	kW	3,14	COPd	
			Tj = operation limit	10,8	kW	3,14	COPd	
		Warmer	Tj = 2 °C	10,8	kW	3,14	COPd	
			Tj = 7 °C	11,1	kW	3,55	COPd	
			Tj = 12 °C	11,3	kW	4,20	COPd	
			Tj = bivalent temperaturea	10,8	kW	3,14	COPd	
			Tj = operation limit	10,8	kW	3,14	COPd	
		Colder	Tj = -7 °C	11,1	kW	3,72	COPd	
			Tj = 2 °C	11,4	kW	4,08	COPd	
			Tj = 7 °C	11,6	kW	4,41	COPd	
			Tj = 12 °C	11,7	kW	4,51	COPd	
			Tj = bivalent temperaturea	10,8	kW	3,14	COPd	
			Tj = operation limit	10,8	kW	3,14	COPd	
		Degradation coefficient when Tj = -7 °C				Cdh	1,00	

Bivalent temperatures	Heating	Average	Tbivalent	-10	°C
		Warmer	Tbivalent	-22	°C
		Colder	Tbivalent	2	°C

Operation limit temperatures	Heating	Average	TOL	-10	°C
		Warmer	TOL	-22	°C
		Colder	TOL	2	°C

Seasonal electricity consumption	Heating	Average	QHE/A	5972	kWh/a
		Warmer	QHE/W	6922	kWh/a
		Colder	QHE/C	3907	kWh/a

Modes other than active mode	Off mode	P _{OFF}	0,017	kWh
	Standby mode	P _{SB}	0,017	kWh
	Thermostat off mode	P _{TO}	0,017	kWh
	Crackcaseheater mode	P _{CK}	0,017	kWh

Heating up time	1:30	h:min
Heating up energy input	4,11	kWh
Standby power input	0,106	kW
Class of the measured tapping cycle and the determined electrical energy consumption W _{EL-TC} for each measured cycle	XL	
	5,52	kWh
COP _{DHW} and energy class of used tapping cycle	3,78	A+
Reference hot water temperature	49	°C
Maximum quantity of usable hot water	272	l
Temperature operating range: minimal and maximal heatsource temperature, minimal start and maximal mean temperature domestic hot water	-10/15	°C
	20	
	53	

Contact details for obtaining more information	Name manufacturer	Suomen Lämpöpumpputekniikka Oy
	Address	Unikontie 2, 62100 LAPUA, FINLAND





ENERG
енергия · ενεργεια

Y IJA
IE IA

LÄMPÖÄSSÄ

Vsi 12 1x230V

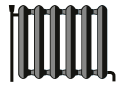

A⁺⁺

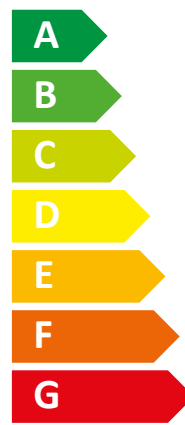

A

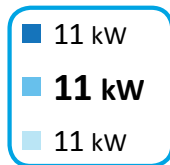
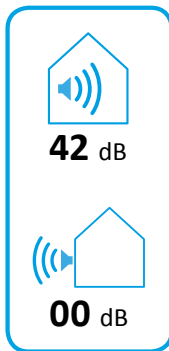





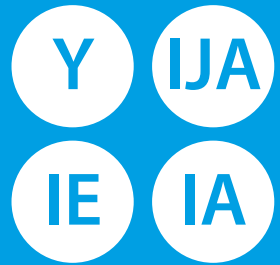

ENERG

енергия · ενεργεια



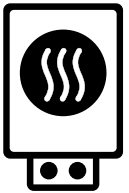

LÄMPÖÄSSÄ

Vsi 12 1x230V

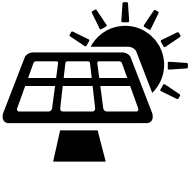









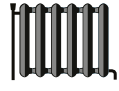

+ 

+ 

+ 

+ 

Product description

Name or trademark	Lämpöässä		
Model	Vsi 12 1x230V		
Seasonal space heating application	Average		
Water heating load profile	XL		
Seasonal space heating energy efficiency class	A++		
Water heating energy efficiency class	A		
Rated heat output under average climate conditions	11		kW
Annual electricity consumption under average climate conditions	6082		kWh
Annual electricity consumption for water heating	1379		kWh
Seasonal space heating energy efficiency under average climate conditions	152		%
Water heating energy efficiency under average climate conditions	133		%
Sound power level indoors	42		dB

Rated heat output under colder and warmer climate conditions	Colder	11	kW
	Warmer	11	kW
Annual electricity consumption for space heating under colder and warmer climate conditions	Colder	7106	kWh/a
	Warmer	3908	kWh/a
Annual electricity consumption for water heating under colder and warmer climate conditions	Colder	1379	kWh/a
	Warmer	1379	kWh/a
Energy efficiency for space heating under colder and warmer climate conditions	Colder	155	%
	Warmer	153	%
Energy efficiency for water heating under colder and warmer climate conditions	Colder	133	%
	Warmer	133	%

Package information

Controller class	III		
Controller contribution to efficiency	1,5		%
Seasonal space heating energy efficiency class of package	A+++		
Seasonal space heating energy efficiency of package in average climate conditions	154		%
Seasonal space heating energy efficiency of package in colder climate conditions	157		%
Seasonal space heating energy efficiency of package in warmer climate conditions	155		%

Function	Heating	Average		
		Warmer		
		Colder		
	Capacity control	Fixed		

Design load	Heating	Average	Pdesignh	11,2	kW
		Warmer	Pdesignh	11,2	kW
		Colder	Pdesignh	11,2	kW

Seasonal efficiency	Heating	Average	SCOP/A	152	%
		Warmer	SCOP/W	153	%
		Colder	SCOP/C	155	%



Declared capacity for heating at indoor conditions 20°C and outdoor temperature Tj	Heating	Average	Tj = -7 °C	11,3	kW	3,26	COPd		
			Tj = 2 °C	11,6	kW	3,82	COPd		
			Tj = 7 °C	11,8	kW	4,25	COPd		
			Tj = 12 °C	12,2	kW	4,62	COPd		
			Tj = bivalent temperaturea	11,2	kW	3,11	COPd		
			Tj = operation limit	11,2	kW	3,11	COPd		
		Warmer	Tj = 2 °C	11,2	kW	3,11	COPd		
			Tj = 7 °C	11,6	kW	3,65	COPd		
			Tj = 12 °C	12,1	kW	4,39	COPd		
			Tj = bivalent temperaturea	11,2	kW	3,11	COPd		
			Tj = operation limit	11,2	kW	3,11	COPd		
		Colder	Tj = -7 °C	11,5	kW	3,65	COPd		
			Tj = 2 °C	11,9	kW	4,12	COPd		
			Tj = 7 °C	12,1	kW	4,54	COPd		
			Tj = 12 °C	12,5	kW	4,72	COPd		
			Tj = bivalent temperaturea	11,2	kW	3,11	COPd		
			Tj = operation limit	11,2	kW	3,11	COPd		
		Degradation coefficient when Tj = -7 °C					Cdh	1,00	

Bivalent temperatures	Heating	Average	Tbivalent	-10	°C
		Warmer	Tbivalent	-22	°C
		Colder	Tbivalent	2	°C

Operation limit temperatures	Heating	Average	TOL	-10	°C
		Warmer	TOL	-22	°C
		Colder	TOL	2	°C

Seasonal electricity consumption	Heating	Average	QHE/A	6082	kWh/a
		Warmer	QHE/W	7106	kWh/a
		Colder	QHE/C	3908	kWh/a

Modes other than active mode	Off mode	P _{OFF}	0,017	kWh
	Standby mode	P _{SB}	0,017	kWh
	Thermostat off mode	P _{TO}	0,017	kWh
	Crackcaseheater mode	P _{CK}	0,017	kWh

Heating up time	1:25	h:min
Heating up energy input	4,68	kWh
Standby power input	0,120	kW
Class of the measured tapping cycle and the determined electrical energy consumption W _{EL-TC} for each measured cycle	XL	
	6,27	kWh
COP _{DHW} and energy class of used tapping cycle	3,33	A+
Reference hot water temperature	49	°C
Maximum quantity of usable hot water	274	l
Temperature operating range: minimal and maximal heatsource temperature, minimal start and maximal mean temperature domestic hot water	-10/15	°C
	20	
	53	

Contact details for obtaining more information	Name manufacturer	Suomen Lämpöpumpputekniikka Oy
	Address	Unikontie 2, 62100 LAPUA, FINLAND





ENERG
енергия · ενεργεια

Y IJA
IE IA

LÄMPÖÄSSÄ

Vsi 14

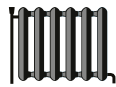

A⁺⁺

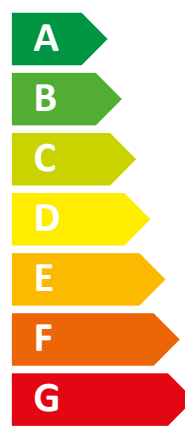

A

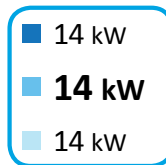
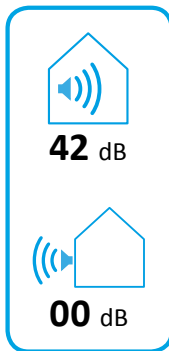



ENERG

енергия · ενεργεια

Y





IJA

IE

IA

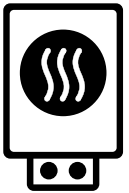
LÄMPÖÄSSÄ

Vsi 14



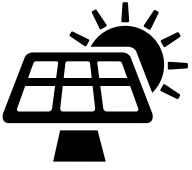







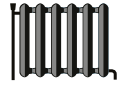

+ 

+ 

+ 

+ 

Product description

Name or trademark	Lämpöässä		
Model	Vsi 14		
Seasonal space heating application	Average		
Water heating load profile	XL		
Seasonal space heating energy efficiency class	A++		
Water heating energy efficiency class	A		
Rated heat output under average climate conditions	14		kW
Annual electricity consumption under average climate conditions	7453		kWh
Annual electricity consumption for water heating	1387		kWh
Seasonal space heating energy efficiency under average climate conditions	155		%
Water heating energy efficiency under average climate conditions	132		%
Sound power level indoors	42		dB

Rated heat output under colder and warmer climate conditions	Colder	14	kW
	Warmer	14	kW
Annual electricity consumption for space heating under colder and warmer climate conditions	Colder	8659	kWh/a
	Warmer	4833	kWh/a
Annual electricity consumption for water heating under colder and warmer climate conditions	Colder	1387	kWh/a
	Warmer	1387	kWh/a
Energy efficiency for space heating under colder and warmer climate conditions	Colder	160	%
	Warmer	155	%
Energy efficiency for water heating under colder and warmer climate conditions	Colder	132	%
	Warmer	132	%

Package information

Controller class	III		
Controller contribution to efficiency	1,5		%
Seasonal space heating energy efficiency class of package	A+++		
Seasonal space heating energy efficiency of package in average climate conditions	151		%
Seasonal space heating energy efficiency of package in colder climate conditions	156		%
Seasonal space heating energy efficiency of package in warmer climate conditions	150		%

Function	Heating	Average		
		Warmer		
		Colder		
	Capacity control	Fixed		

Design load	Heating	Average	Pdesignh	14,02	kW
		Warmer	Pdesignh	14,02	kW
		Colder	Pdesignh	14,02	kW

Seasonal efficiency	Heating	Average	SCOP/A	155	%
		Warmer	SCOP/W	155	%
		Colder	SCOP/C	160	%



Declared capacity for heating at indoor conditions 20°C and outdoor temperature Tj	Heating	Average	Tj = -7 °C	14,1	kW	3,39	COPd	
			Tj = 2 °C	14,3	kW	3,88	COPd	
			Tj = 7 °C	14,5	kW	4,29	COPd	
			Tj = 12 °C	14,9	kW	4,63	COPd	
			Tj = bivalent temperaturea	14,0	kW	3,25	COPd	
			Tj = operation limit	14,0	kW	3,25	COPd	
		Warmer	Tj = 2 °C	14,0	kW	3,25	COPd	
			Tj = 7 °C	14,3	kW	3,68	COPd	
			Tj = 12 °C	14,8	kW	4,38	COPd	
			Tj = bivalent temperaturea	14,0	kW	3,25	COPd	
			Tj = operation limit	14,0	kW	3,25	COPd	
		Colder	Tj = -7 °C	14,4	kW	3,80	COPd	
			Tj = 2 °C	14,6	kW	4,20	COPd	
			Tj = 7 °C	14,9	kW	4,59	COPd	
			Tj = 12 °C	15,3	kW	4,75	COPd	
			Tj = bivalent temperaturea	14,0	kW	3,25	COPd	
			Tj = operation limit	14,0	kW	3,25	COPd	
		Degradation coefficient when Tj = -7 °C				Cdh	1,00	

Bivalent temperatures	Heating	Average	Tbivalent	-10	°C
		Warmer	Tbivalent	-22	°C
		Colder	Tbivalent	2	°C

Operation limit temperatures	Heating	Average	TOL	-10	°C
		Warmer	TOL	-22	°C
		Colder	TOL	2	°C

Seasonal electricity consumption	Heating	Average	QHE/A	7453	kWh/a
		Warmer	QHE/W	8659	kWh/a
		Colder	QHE/C	4833	kWh/a

Modes other than active mode	Off mode	P _{OFF}	0,017	kWh
	Standby mode	P _{SB}	0,017	kWh
	Thermostat off mode	P _{TO}	0,017	kWh
	Crackcaseheater mode	P _{CK}	0,017	kWh

Heating up time	1:09	h:min
Heating up energy input	4,70	kWh
Standby power input	0,121	kW
Class of the measured tapping cycle and the determined electrical energy consumption W _{EL-TC} for each measured cycle	XL	
	6,30	kWh
COP _{DHW} and energy class of used tapping cycle	3,31	A+
Reference hot water temperature	49	°C
Maximum quantity of usable hot water	282	l
Temperature operating range: minimal and maximal heatsource temperature, minimal start and maximal mean temperature domestic hot water	-10/15	°C
	20	
	53	

Contact details for obtaining more information	Name manufacturer	Suomen Lämpöpumpputekniikka Oy
	Address	Unikontie 2, 62100 LAPUA, FINLAND



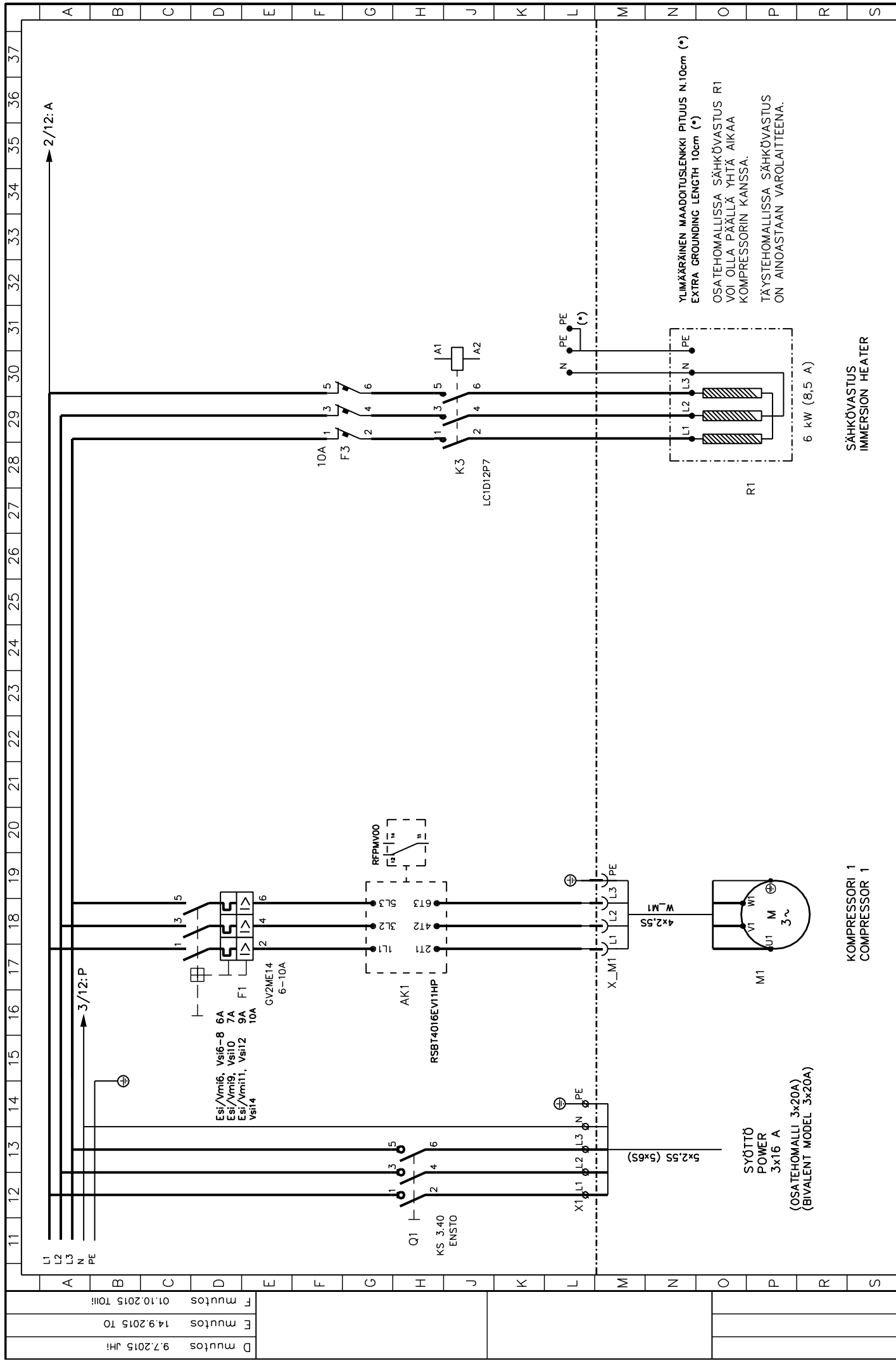

A	D muutokset 9.7.2015 JHI	
B	E muutokset 14.9.2015 TO	
C	F muutokset 01.10.2015 TOIII	
D		
E		
F		
G		
H		
J		
K		
L		
M		
N		
O		
P		
R		
S		

A		B		C	
D		E		F	
G		H		I	
J		K		L	
M		N		O	
P		Q		R	
S		T		U	

PÄÄVIRTAPIIRI MAALÄMPÖPUMPPU LÄMPÖÄSSÄ Esi/Vmi6-11, Vsi6-14		CONTROL CIRCUIT GROUND SOURCE HEAT PUMP LÄMPÖÄSSÄ Esi/Vmi6-11, Vsi6-14		KOMPRESSORI 1 COMPRESSOR 1	
SÄHKÖVASTUS IMMERSION HEATER		PÄÄVIRTAPIIRI MAALÄMPÖPUMPPU LÄMPÖÄSSÄ Esi/Vmi6-11, Vsi6-14		KOMPRESSORI 1 COMPRESSOR 1	
Suunn. Toim. /08.12.2014		Suunn. Toim. /08.12.2014		Kokonaisuus	
Pirtt. Toim.		Pirtt. Toim.		Sähköposito	
Tark.		Tark.		Lehti/ Pöytäkirja	
				Työnumero	
				S Esi/Vmi6-11_Vsi6-14_P3_15F	

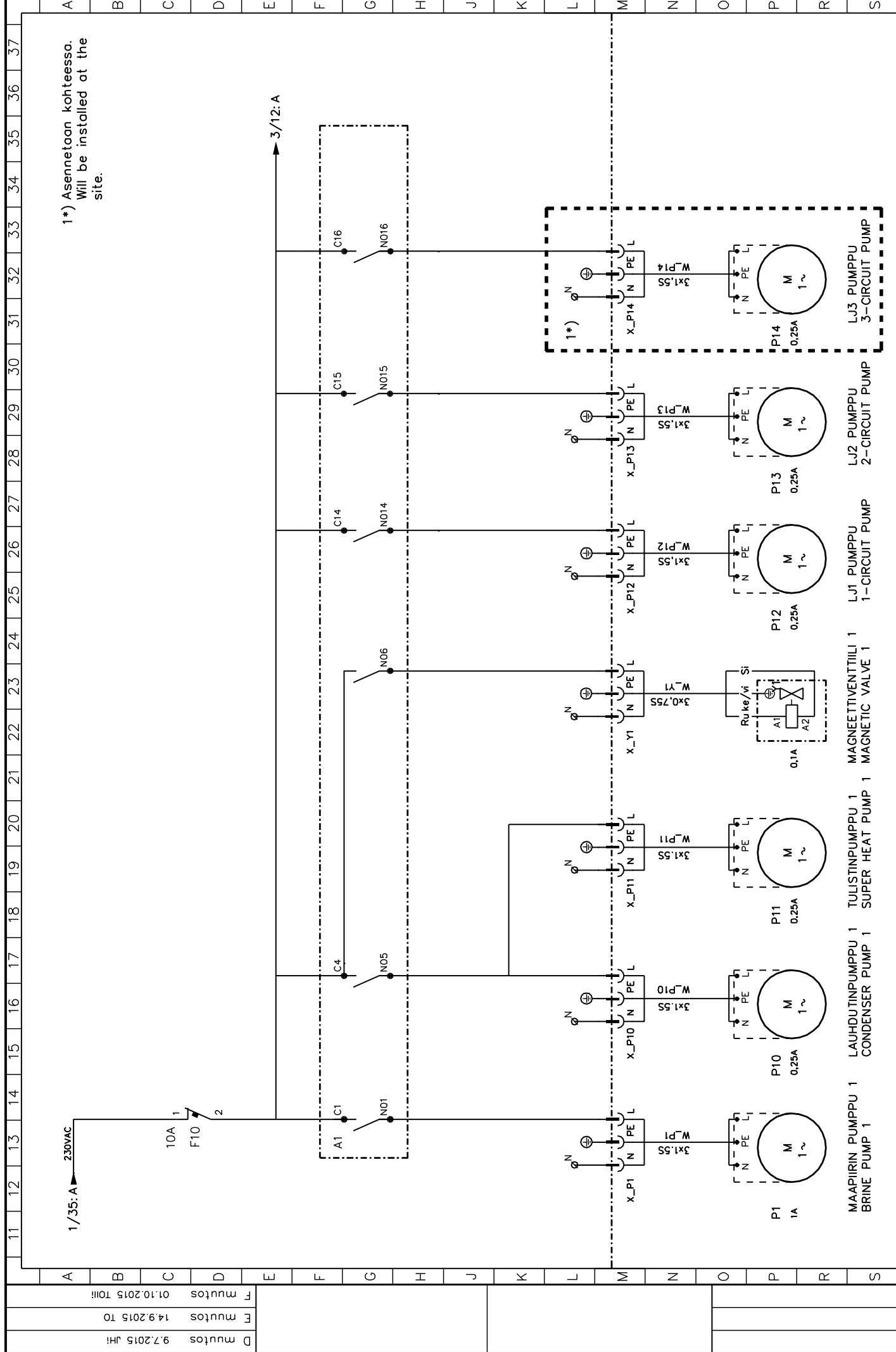

1*) Asennetaan kohteessa.
Will be installed at the site.

- MAAPIIRIN PUMPPU 1 LAUHDTINPUMPPU 1 CONDENSER PUMP 1
- P1 1A M 1~
- P10 0.25A M 1~
- TULISTINPUMPPU 1 SUPER HEAT PUMP 1
- P11 0.25A M 1~
- MAGNEETTIVENTTIILI 1 MAGNETIC VALVE 1
- Röke/vi Si
- 0.1A
- LJ1 PUMPPU 1-CIRCUIT PUMP
- P12 0.25A M 1~
- LJ2 PUMPPU 2-CIRCUIT PUMP
- P13 0.25A M 1~
- LJ3 PUMPPU 3-CIRCUIT PUMP
- P14 0.25A M 1~

A muutoks	9.7.2015 JHI
B muutoks	14.9.2015 TO
C muutoks	01.10.2015 TOIII

Suunn. TOIII / 08.12.2014		Kokonaisuus	Sähköposito	Työnumero
Piirt. TOIII	Lehti / 2 / 7	Piirustusnumero		
Tark.	S Esi/Vmi6-11_Vsi6-14_P3_15F			

OHJAUSPIIRIKAAVIO MAALÄMPÖPUMPPU LÄMPÖÄSSÄ Esi/Vmi6-11, Vsi6-14	CONTROL CIRCUIT GROUND SOURCE HEAT PUMP LÄMPÖÄSSÄ Esi/Vmi6-11, Vsi6-14
---	--

LÄMPÖÄSSÄ

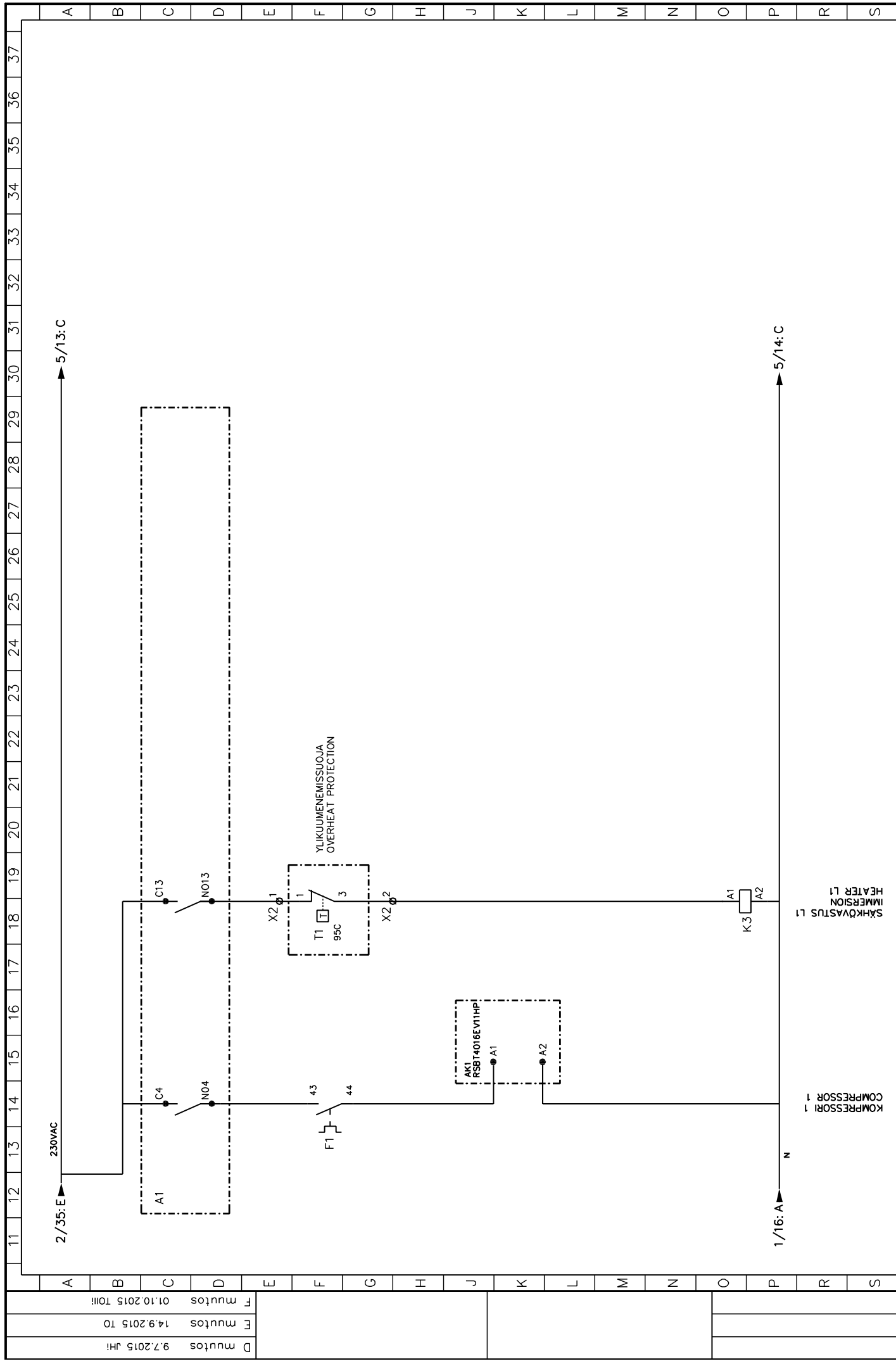

2/35:E

230VAC

5/13: C

1/16: A

N

5/14: C

A muutokset	
B muutokset	
C muutokset	
D muutokset	9.7.2015 JHI
E muutokset	14.9.2015 TO
F muutokset	01.10.2015 TOIII

A muutokset		Suunn. /08.12.2014		Kokonaisuus		Sähköposito		Työnumero	
B muutokset		Pii: TOIII		Lehti: 3/7		Pii:rustusnumero		S Esi/Vmi6-11_Vsi6-14_P3_15F	
C muutokset		Tark.							
OHJAUSPIIRIKAAVIO MAALÄMPÖPUMPPU LÄMPÖÄSSÄ Esi/Vmi6-11, Vsi6-14			CONTROL CIRCUIT GROUND SOURCE HEAT PUMP LÄMPÖÄSSÄ Esi/Vmi6-11, Vsi6-14						

LÄMPÖÄSSÄ

HÄLYTYSKYTKENTÄ
ALARM CONNECTION

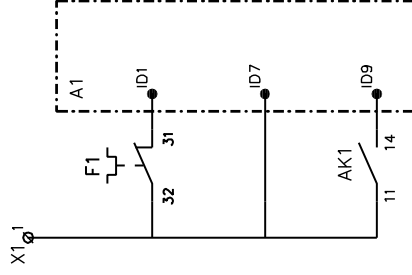

Kompressorin moottorisuoja F1
Compressor protection switch F1

Vaihevahti
Phase failure detector

KAIKKI 24V
JOHDOTUKSET
0,75MM2

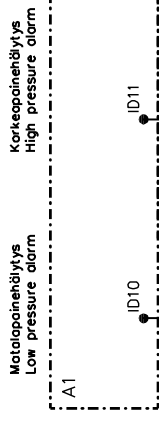

- PS1 Pressostaatin toiminta
PS1 Pressostat activity.
Paineeton Non-pressured, off
Käynnittö Normal running, on
Matalapainehälytys Low pressure alarm, off
- PS2 Pressostaatin toiminta
PS2 Pressostat activity.
Paineeton Non-pressured, on
Käynnittö Normal running, on
Korkeapainehälytys High pressure alarm, off

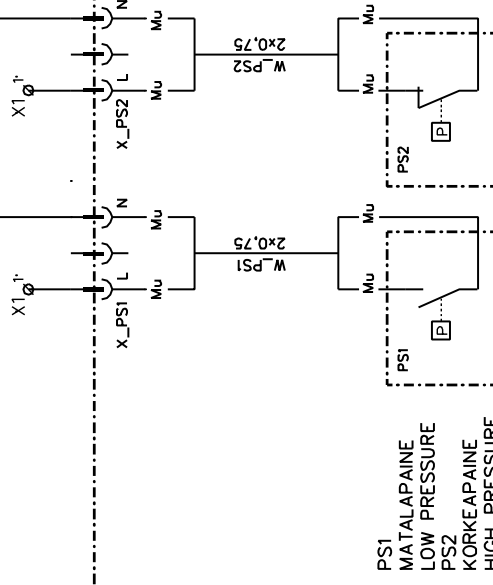

PS1
MATALAPAIN
LOW PRESSURE
PS2
KORKEAPAIN
HIGH PRESSURE

D	muitos	9.7.2015 JHI
E	muitos	14.9.2015 TO
F	muitos	01.10.2015 TOIII

A	muitos	
B	muitos	
C	muitos	

LÄMPÖÄSSÄ

CONTROL CIRCUIT
GROUND SOURCE HEAT PUMP
LÄMPÖÄSSÄ Esi/Vmi6-11, Vsi6-14

OHJAUSPIIRIKAAVIO
MAALÄMPÖPUMPPU
LÄMPÖÄSSÄ Esi/Vmi6-11, Vsi6-14

Suunn. TOIII	/08.12.2014
Piirt. TOIII	
Tark.	

Kokonaisuus	Sähköposito	Työnumero
Lehti/ 4/7	Piirustusnumero	
		S Esi/Vmi6-11_Vsi6-14_P3_15F

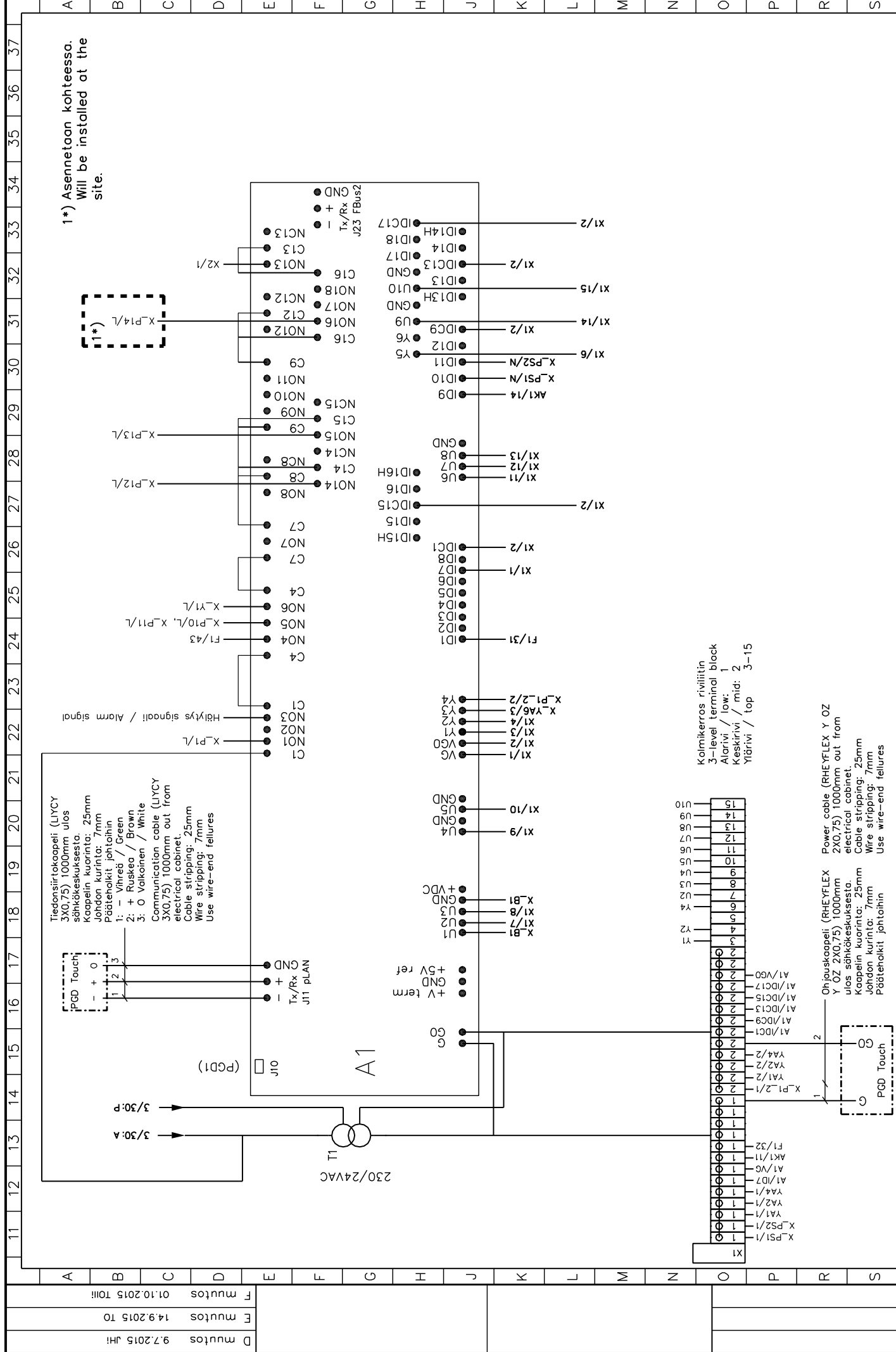

A	muitos	9.7.2015 JHI
B	muitos	14.9.2015 TO
C	muitos	01.10.2015 TOIII

A	muitos		
B	muitos		
C	muitos		
		Suunn. Toim. / 08.12.2014	Kokonaissuus
		Piirt. Toim.	Sähköposito
		Tark.	Työnumero
		Lehti / 5/7	Piirustusnumero
		OHJAUSKORTTI MAALÄMPÖPUMPPU LÄMPÖÄSSÄ Esi/Vmi6-11, Vsi6-14	
		CONTROL BOARD GROUND SOURCE HEAT PUMP LÄMPÖÄSSÄ Esi/Vmi6-11, Vsi6-14	
		LÄMPÖÄSSÄ	
		S Esi/Vmi6-11_Vsi6-14_P3_15F	

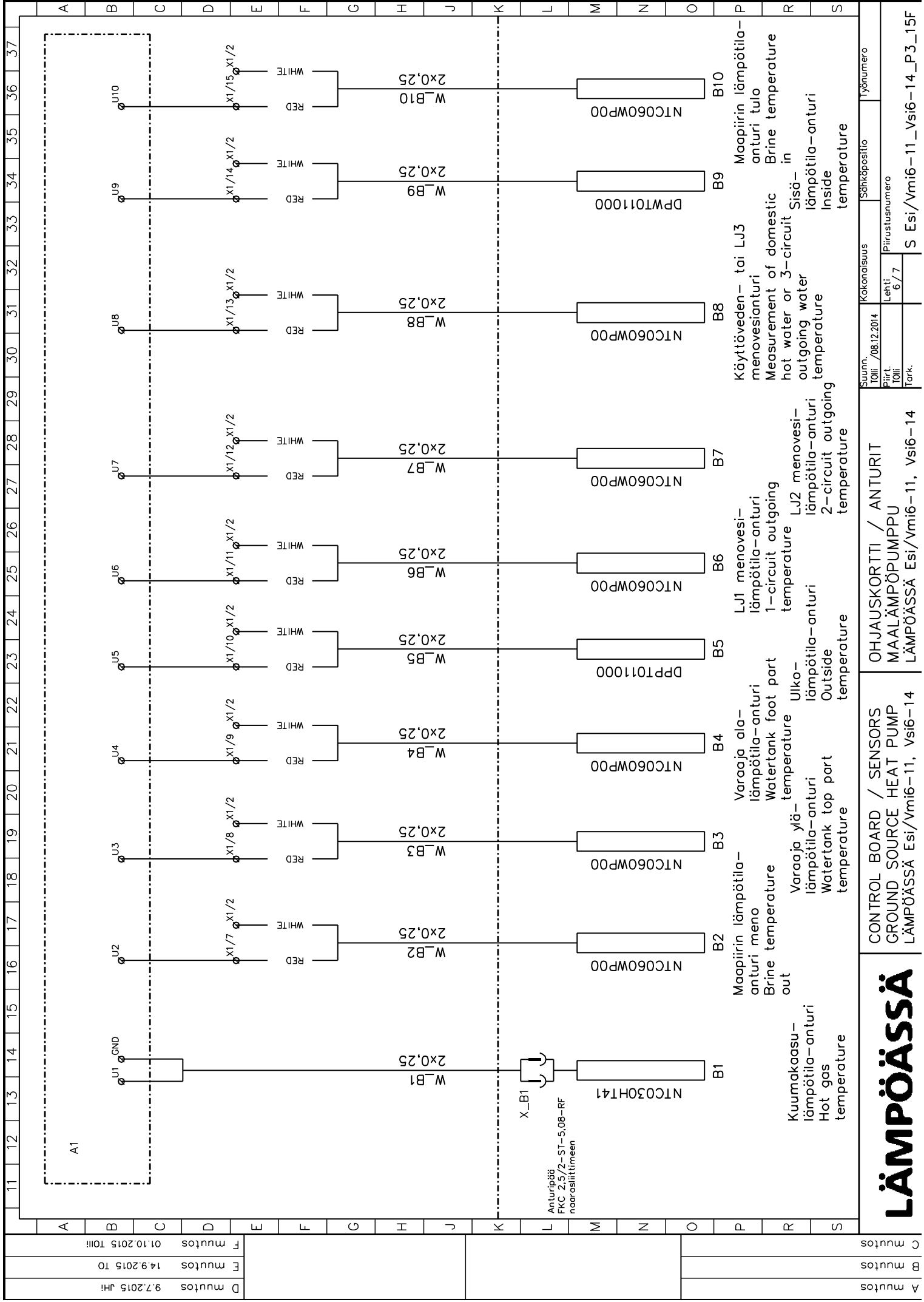

A mütös																		
B mütös																		
C mütös																		

	Kokonaisuus	Sähköposito	Työnumero
Suunn. Toili / 08.12.2014			
Pirtt. Toili	Lehti / 6 / 7	Pirustusnumero	
Tark.	S Esi/Vmi6-11_Vsi6-14_P3_15F		

CONTROL BOARD / SENSORS GROUND SOURCE HEAT PUMP LÄMPÖÄSSÄ Esi/Vmi6-11, Vsi6-14	OHJAUSKORTTI / ANTURIT MAALÄMPÖPUMPPU LÄMPÖÄSSÄ Esi/Vmi6-11, Vsi6-14	
--	--	--

LÄMPÖÄSSÄ

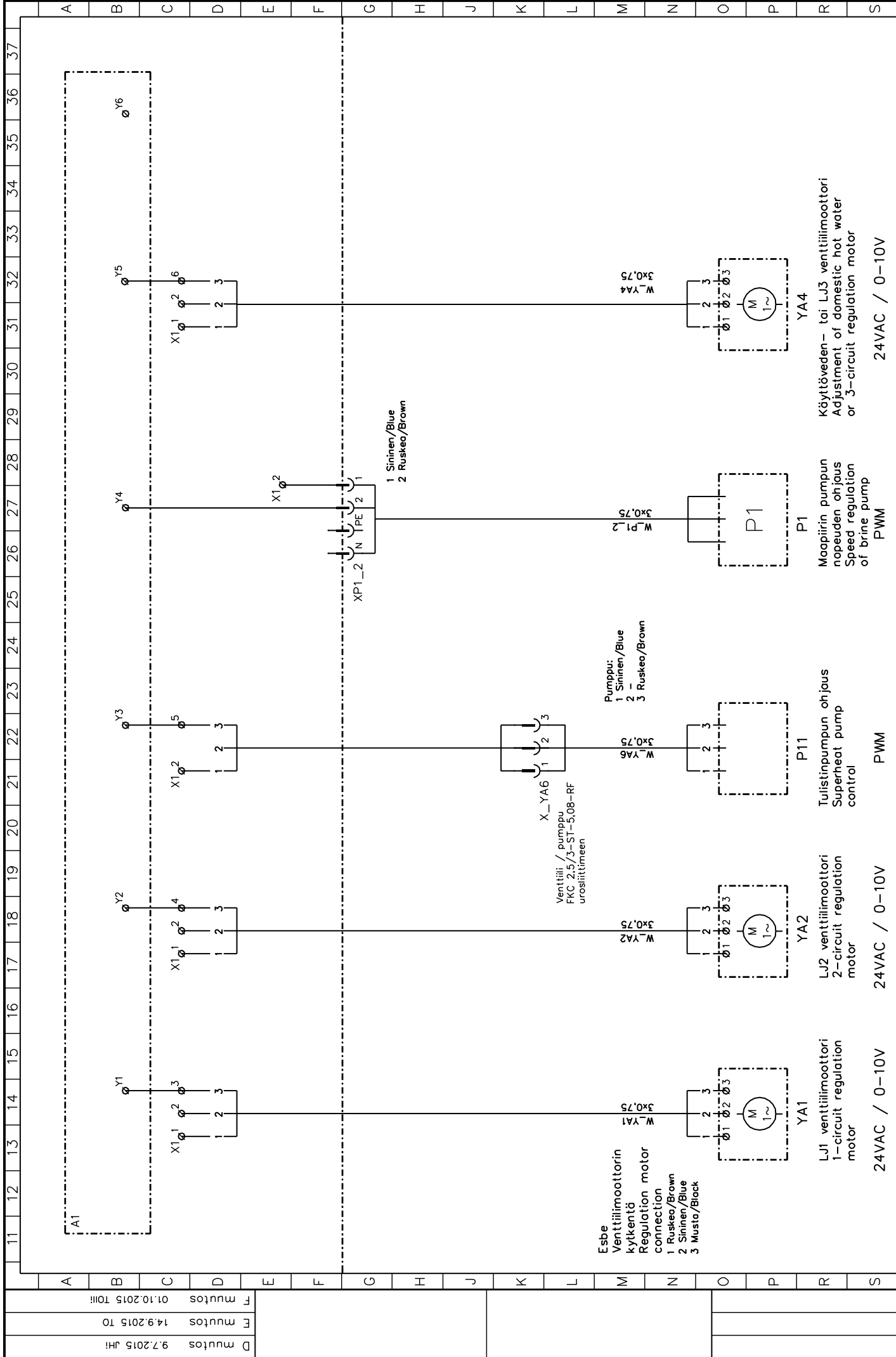

A	muitos	9.7.2015 JH
B	muitos	14.9.2015 TO
C	muitos	01.10.2015 TOIII
D	muitos	
E	muitos	
F	muitos	
G	muitos	
H	muitos	
J	muitos	
K	muitos	
L	muitos	
M	muitos	
N	muitos	
O	muitos	
P	muitos	
R	muitos	
S	muitos	

CONTROL BOARD / MOTORS
GROUND SOURCE HEAT PUMP
LÄMPÖÄSSÄ Esi/Vmi6-11, Vsi6-14

OHJAUSKORTTI / MOOTTORIT
MAALÄMPÖPUMPPU
LÄMPÖÄSSÄ Esi/Vmi6-11, Vsi6-14

Suunn. TOIII / 08.12.2014	Kokonaisuus	Sähköposito	Työnumero
Piirt. TOIII	Lehti	Piirustusnumero	
Tark.	7/7	S Esi/Vmi6-11_Vsi6-14_P3_15F	

LÄMPÖÄSSÄ

A	mutos
B	mutos
E	mutos
F	mutos

C	mutos
---	-------

D	mutos
---	-------

S	
---	--

R	
---	--

P	
---	--

O	
---	--

N	
---	--

M	
---	--

L	
---	--

K	
---	--

J	
---	--

H	
---	--

G	
---	--

F	
---	--

E	
---	--

D	
---	--

C	
---	--

B	
---	--

A	
---	--

11	
----	--

12	
----	--

13	
----	--

14	
----	--

15	
----	--

16	
----	--

17	
----	--

18	
----	--

19	
----	--

20	
----	--

21	
----	--

22	
----	--

23	
----	--

24	
----	--

25	
----	--

26	
----	--

27	
----	--

28	
----	--

29	
----	--

30	
----	--

31	
----	--

32	
----	--

33	
----	--

34	
----	--

35	
----	--

36	
----	--

37	
----	--

A	
---	--

B	
---	--

C	
---	--

D	
---	--

E	
---	--

F	
---	--

G	
---	--

H	
---	--

J	
---	--

K	
---	--

L	
---	--

M	
---	--

N	
---	--

O	
---	--

P	
---	--

R	
---	--

S	
---	--

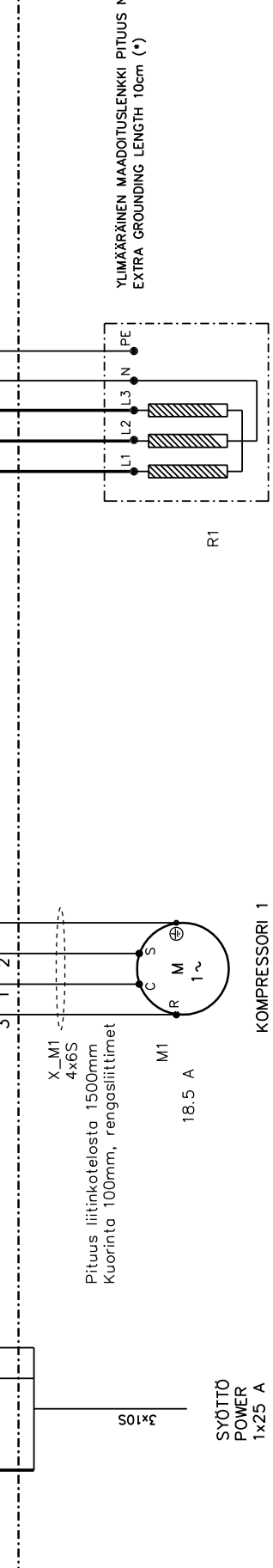
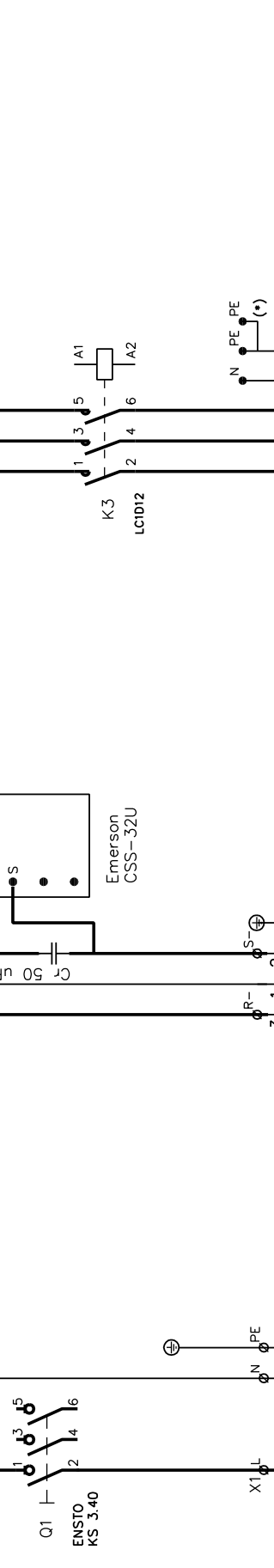
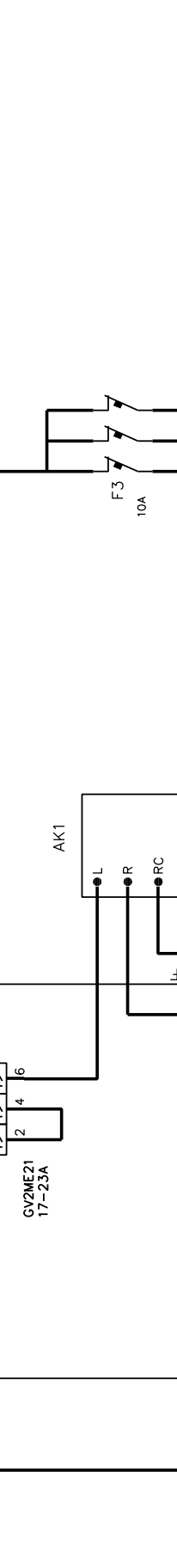
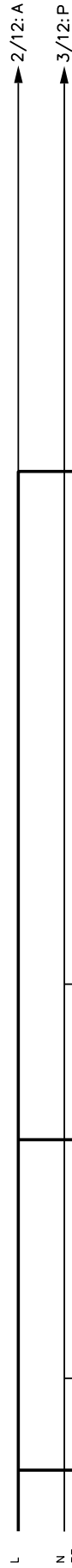

SÄHKÖVASTUS
IMMERSION HEATER

YLIÄÄRRÄINEN MAADOITUSLENKKI PITUUS N.10cm (*)
EXTRA GROUNDING LENGTH 10cm (*)

Suunn. /8.2.2016		Kokonaisuus	Sähköpositio	Työnumero
Piirt. /1/7	Tark.	Pirustusnumero		
S EsVsVm8_P1_16A				
PÄÄVIRTAPIIRI MAALÄMPÖPUMPPU		CONTROL CIRCUIT GROUND HEAT PUMP		

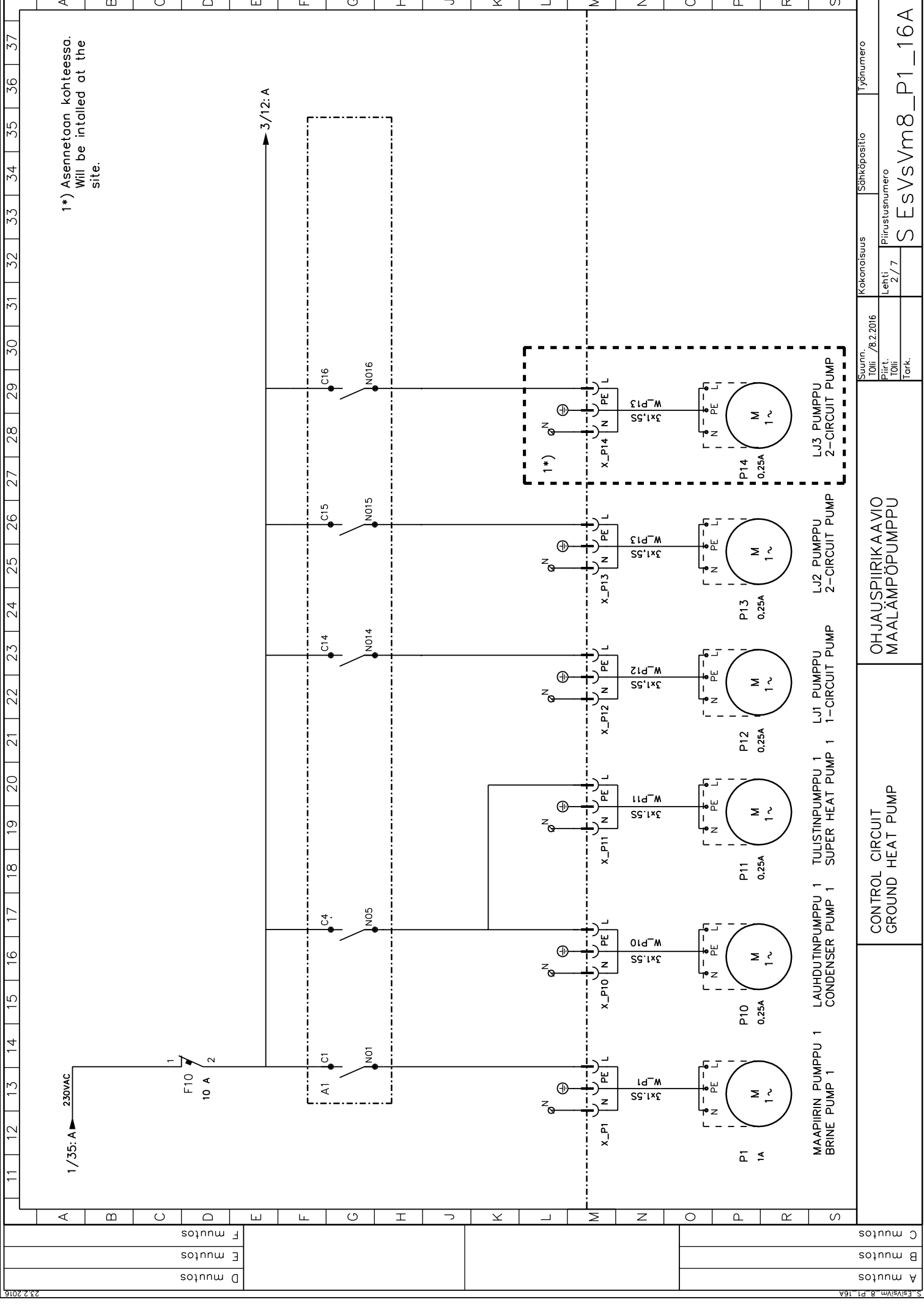

1*) Asennetaan kohteessa.
Will be intalled at the
site.

A	B	C	D	E	F	G	H	J	K	L	M	N	O	P	R	S
A muutokset			E muutokset			F muutokset						C muutokset				

Suunn.	Kokonaisuus	Sähköpiirros	Työnumero
Toili / 8.2.2016			
Piirt.	Lehti	Piirustusnumero	
Toili	2/7		
Tark.			

OHJAUSPIIRIKAAVIO
MAALÄMPÖPUMPPU

CONTROL CIRCUIT
GROUND HEAT PUMP

MAAPIIRIN PUMPPU 1
BRINE PUMP 1

LAUHDUTINPUMPPU 1
CONDENSER PUMP 1

TULISTINPUMPPU 1
SUPER HEAT PUMP 1

L2 PUMPPU
2-CIRCUIT PUMP

L3 PUMPPU
2-CIRCUIT PUMP

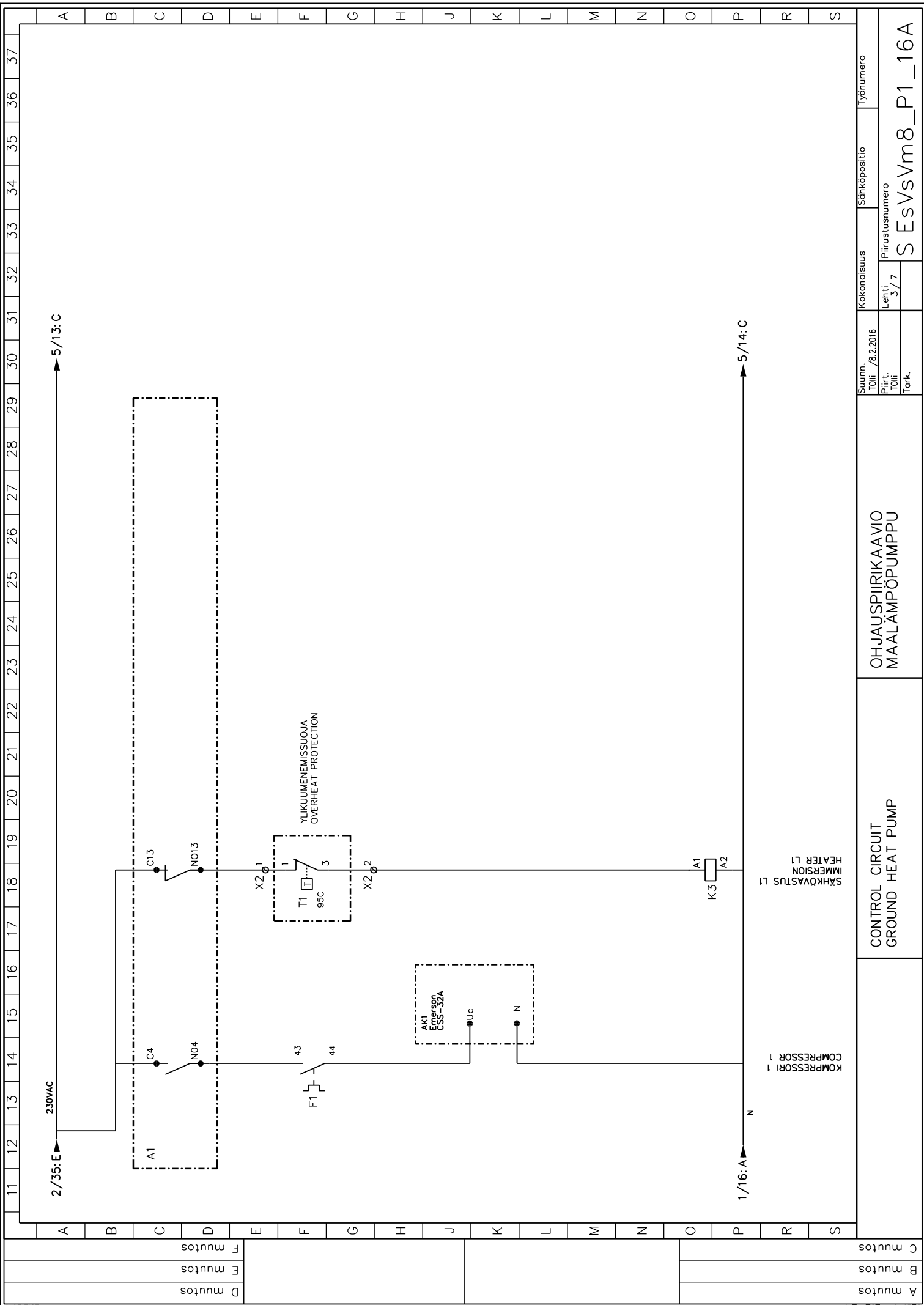

OHJAUSPIIRIKAAVIO
MAALÄMPÖPUMPPU

CONTROL CIRCUIT
GROUND HEAT PUMP

KOMPRESSORI 1
IMMERSION
HEATER L1

Suunn. Toili /8.2.2016	Kokonaisuus	Sähköpositio	Työnumero
Piirt. Toili	Lehti 3/7	Piirustusnumero	
Tark.		S EsVsm8_P1_16A	

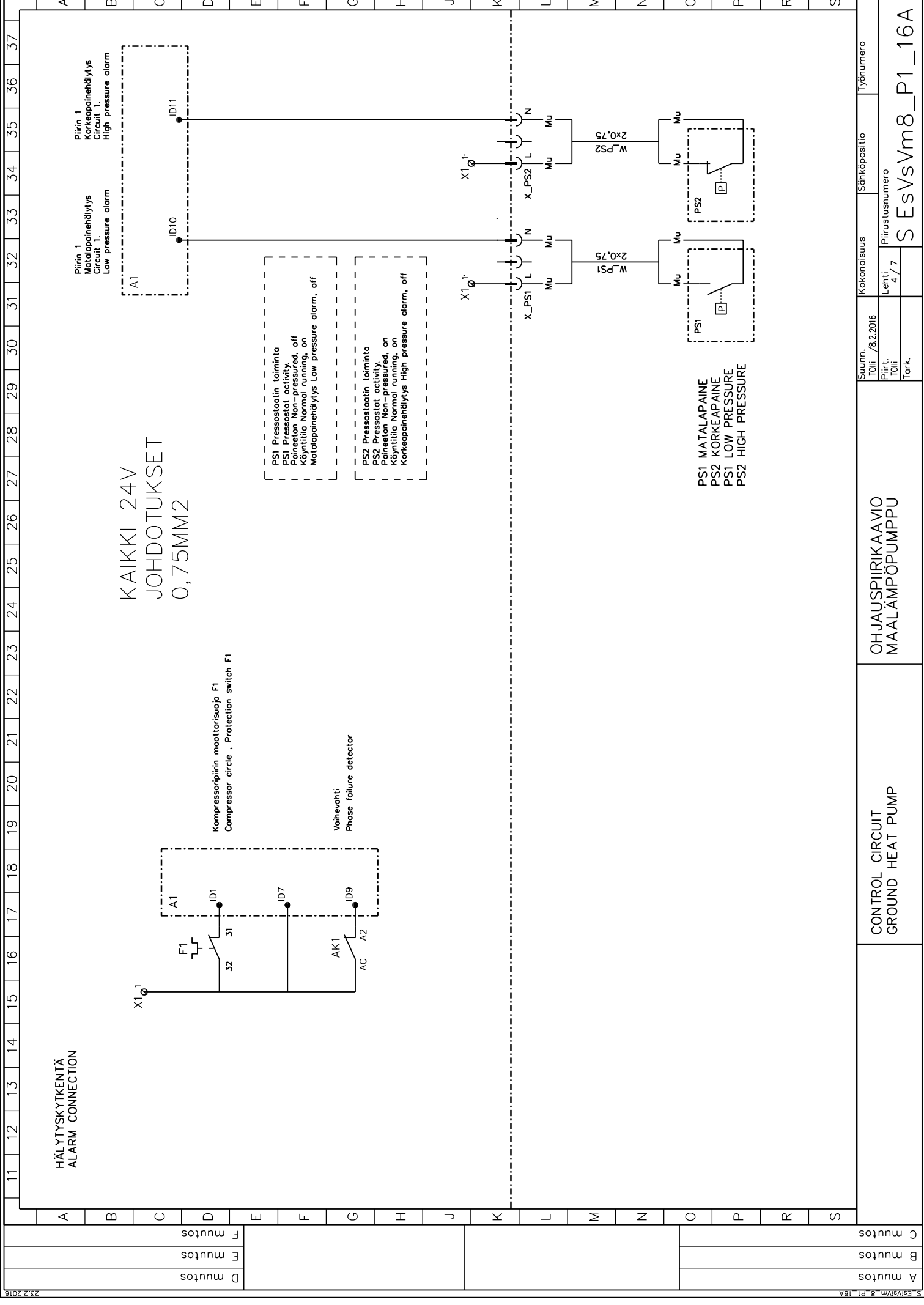

A muutos	Suunn. /8.2.2016		Kokonaisuus	Sähköpiirros	Työnumero
B muutos	Piirt.	Tark.	Lehti	Piirustusnumero	
C muutos	4 / 7		S EsVsVm8_P1_16A		

OHJAUSPIIRIKAAVIO
MAALÄMPÖPUMPPU

CONTROL CIRCUIT
GROUND HEAT PUMP

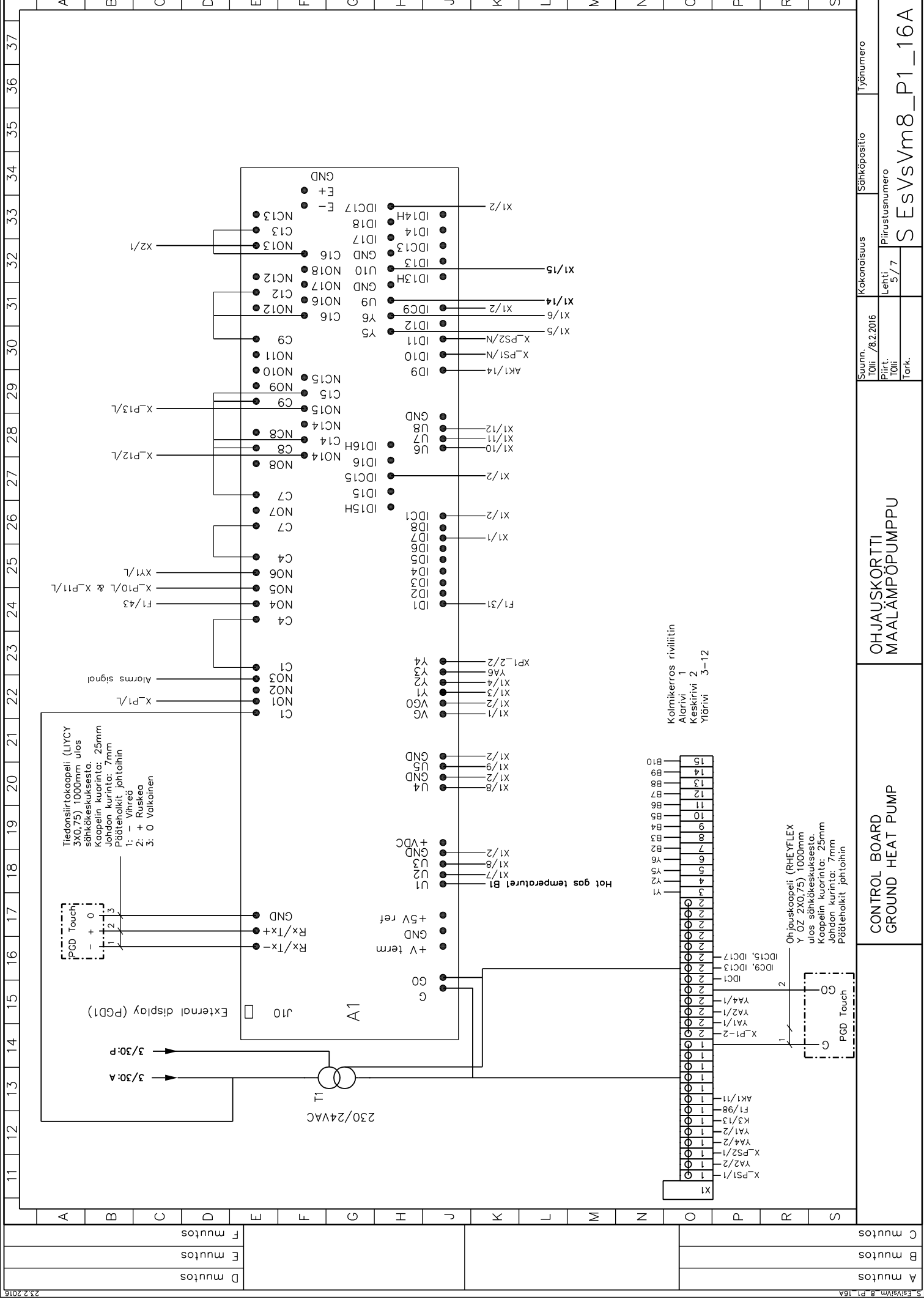

Tiedonsiirtokaapeli (LIYCY 3X0,75) 1000mm ulos sähkökeskuksesta. Kaapelin kurinti: 25mm Johdon kurinti: 7mm Päätehoikit johtoihin
 1: - Vihreä
 2: + Ruskea
 3: 0 Valkoinen

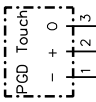

External display (PGD1)

3/30:A
 3/30:P

230/24VAC

L1

Kolmikierros riviilitin
 Alarivi 1
 Keskirivi 2
 Ylärivi 3-12

Ohjuskaapeli (RHEYFLEX Y ÖZ 2X0,75) 1000mm ulos sähkökeskuksesta. Kaapelin kurinti: 25mm Johdon kurinti: 7mm Päätehoikit johtoihin

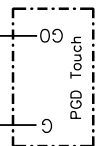

A muutos		B muutos		C muutos	
D muutos		E muutos		F muutos	
Suunn.		Suunn.		Suunn.	
Tark.		Tark.		Tark.	
Pirtt.		Pirtt.		Pirtt.	
Lehti		Lehti		Lehti	
5/7		5/7		5/7	
Pirustusnumero		Pirustusnumero		Pirustusnumero	
S EsVsVm8_P1_16A		S EsVsVm8_P1_16A		S EsVsVm8_P1_16A	
OHJAUSKORTTI		OHJAUSKORTTI		OHJAUSKORTTI	
MAALÄMPÖPUMPPU		MAALÄMPÖPUMPPU		MAALÄMPÖPUMPPU	
CONTROL BOARD		CONTROL BOARD		CONTROL BOARD	
GROUND HEAT PUMP		GROUND HEAT PUMP		GROUND HEAT PUMP	
Sähköpostio		Sähköpostio		Sähköpostio	
Työnnumero		Työnnumero		Työnnumero	
Tolli /8.2.2016		Tolli /8.2.2016		Tolli /8.2.2016	
Kokonaisuus		Kokonaisuus		Kokonaisuus	

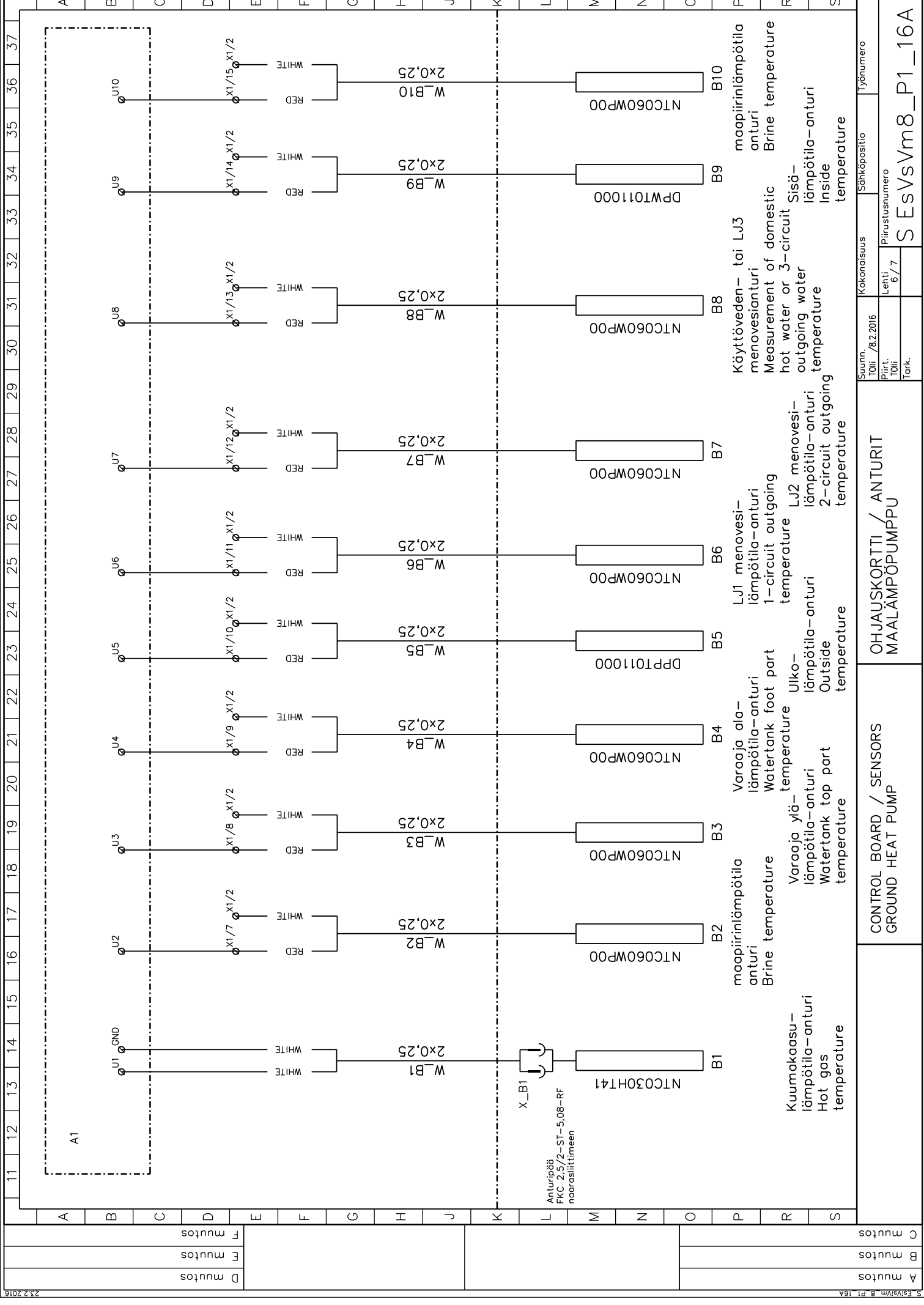

Suunn.	Kokonaisuus	Sähköpiirros	Työnumero
Tolli / 28.2.2016			
Piirt.	Lehti	Piirustusnumero	
Tolk.	6/7		

OHJAUSKORTTI / ANTURIT
MAALÄMPÖPUMPPU

CONTROL BOARD / SENSORS
GROUND HEAT PUMP

S ESvsm8_P1_16A

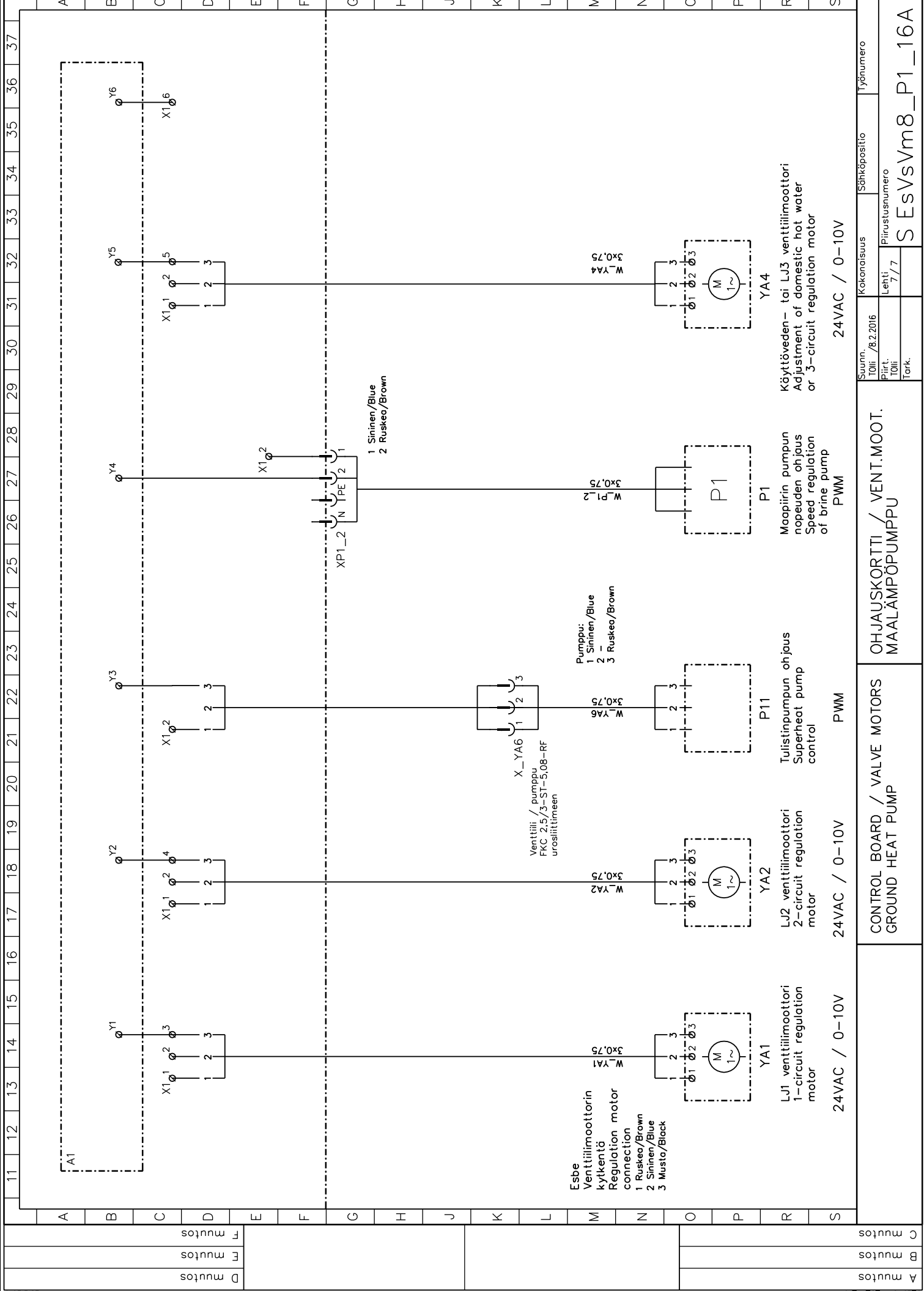

A	A muutos	
B	B muutos	
C	C muutos	
D	D muutos	
E	E muutos	
F	F muutos	

Suunn. /8.2.2016		Kokonaisuus	Sähköpiirros	Työnumero
Piirt. /7/7	Lehti	Piirustusnumero	S EsVsm8_P1_16A	
Tark.				

OHJAUSKORTTI / VENT.MOOT.
MAALÄMPÖPUMPPU

CONTROL BOARD / VALVE MOTORS
GROUND HEAT PUMP

24VAC / 0-10V
24VAC / 0-10V
P11
P11
P11

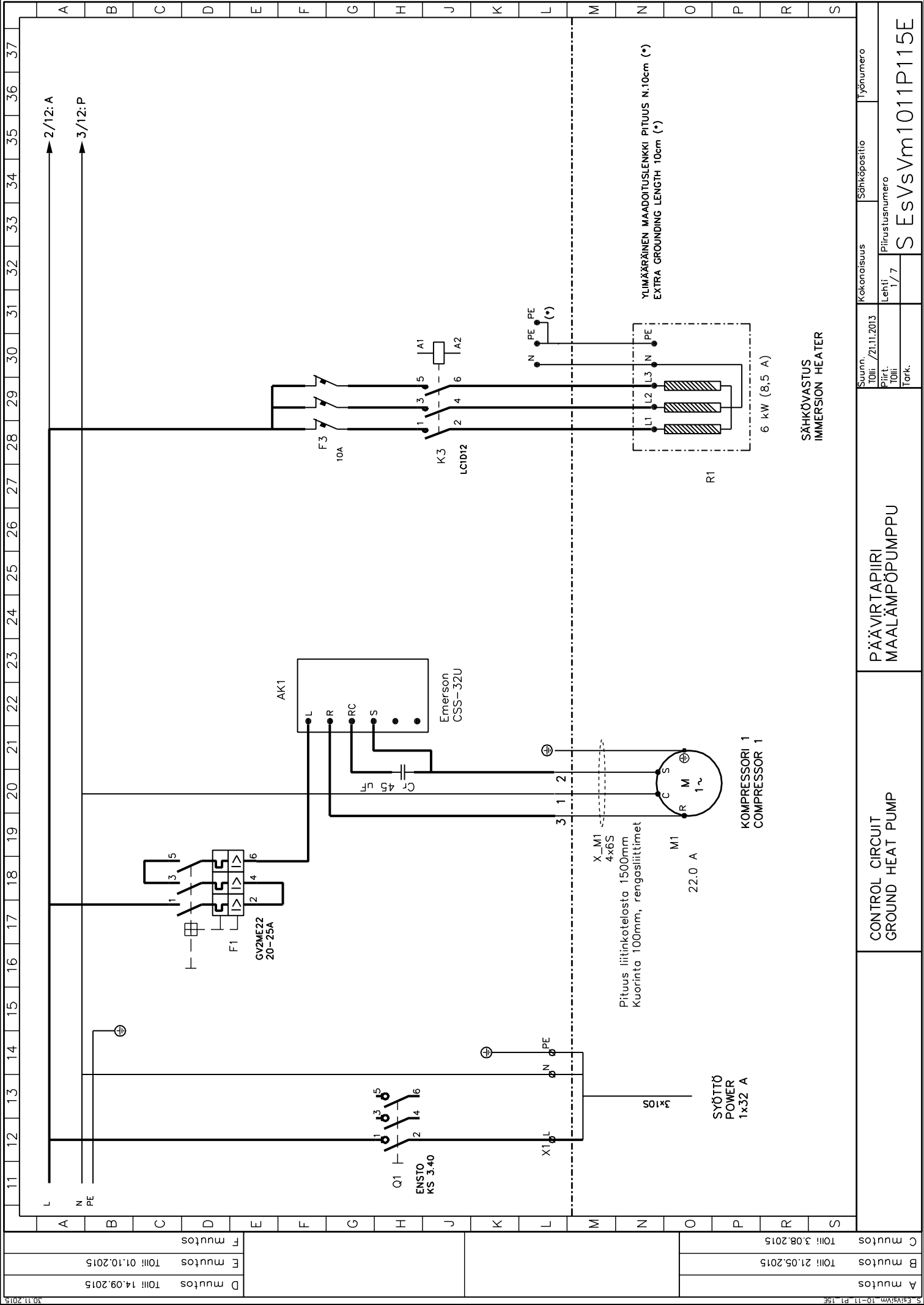

A	mutos	TOIII 21.05.2015
B	mutos	TOIII 01.10.2015
C	mutos	TOIII 3.08.2015
D	mutos	TOIII 14.09.2015
E	mutos	TOIII 01.10.2015
F	mutos	

Suurn. TOIII /21.11.2013		Kokonaisuus	Sähköposti	Työnumero
Piirt. TOIII	Tark.	Lehti 1/7	Piirustusnumero	
		S ESvsVm1011P115E		
CONTROL CIRCUIT GROUND HEAT PUMP		PÄÄVIRTAPIIRI MAALÄMPÖPUMPPU		

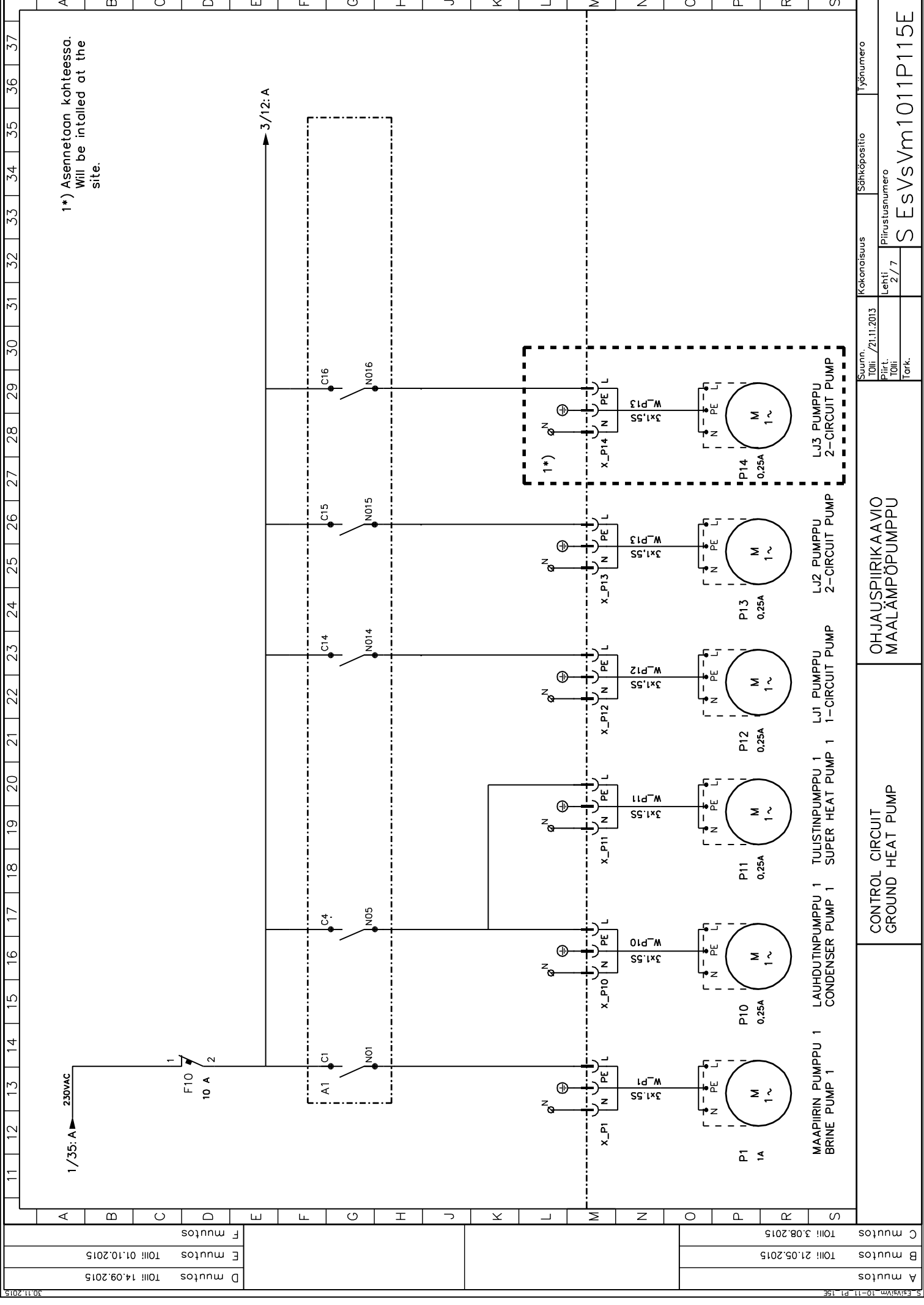

1*) Asennetaan kohteessa.
Will be intalled at the
site.

A	mutos	TOIII: 21.05.2015	
B	mutos	TOIII: 01.10.2015	
C	mutos	TOIII: 3.08.2015	
D	mutos	TOIII: 14.09.2015	
E	mutos	TOIII: 01.10.2015	
F	mutos		

Suurin. Toili: /21.11.2013	Kokonaisuus	Sähköpositio	Työnnumero
Piirt. Toili	Lehti 2/7	Piirustusnumero	
Tark.			S Esvsm1011P115E

OHJAUSPIIRIKAAVIO
MAALÄMPÖPUMPPU

CONTROL CIRCUIT
GROUND HEAT PUMP

MAAPIIRIN PUMPPU 1
BRINE PUMP 1

LAUHDUTINPUMPPU 1
CONDENSER PUMP 1

TULISTINPUMPPU 1
SUPER HEAT PUMP 1

LJ1 PUMPPU
1-CIRCUIT PUMP

LJ2 PUMPPU
2-CIRCUIT PUMP

LJ3 PUMPPU
2-CIRCUIT PUMP

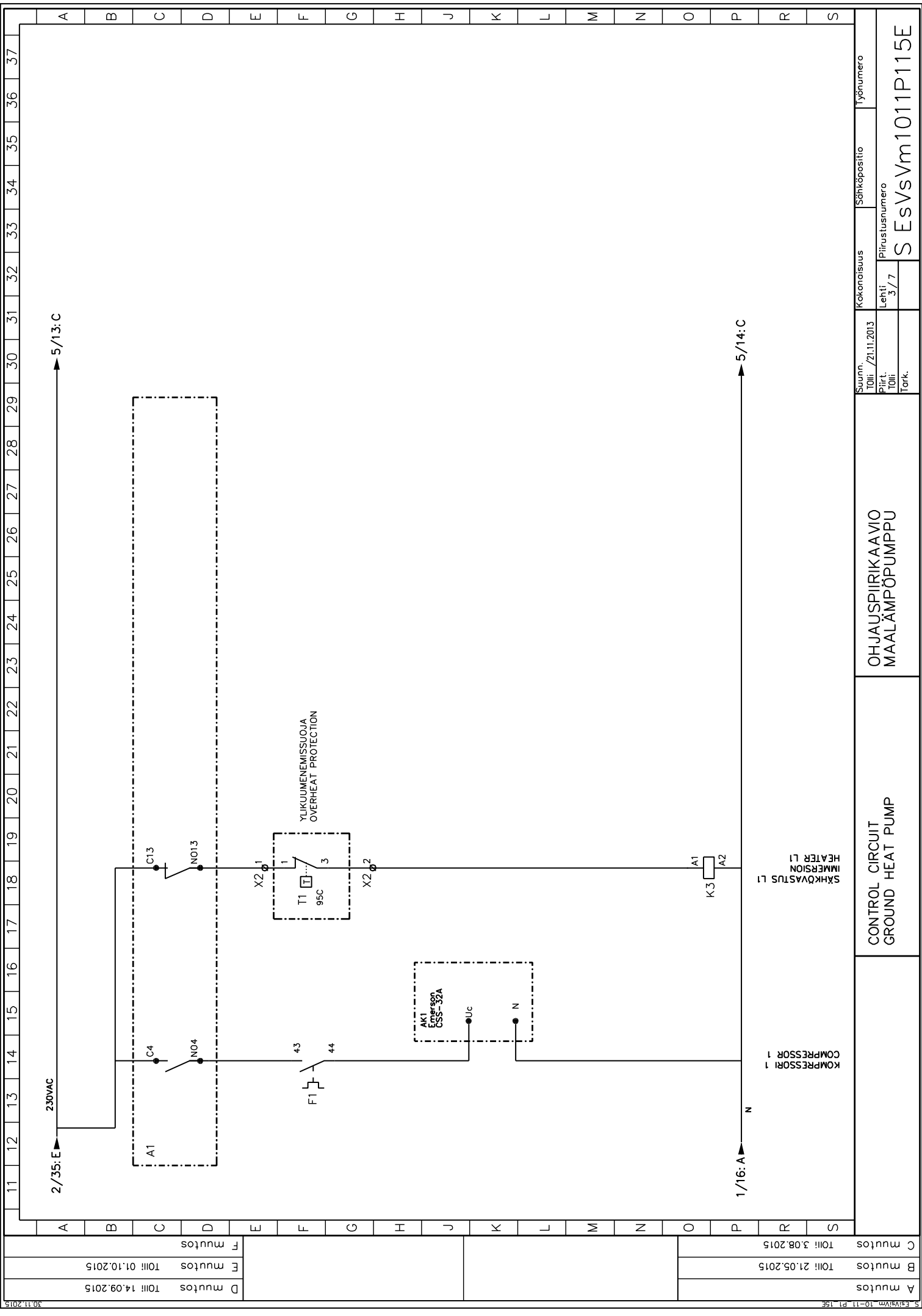

A	mutos	TOIII 21.05.2015
B	mutos	TOIII 3.08.2015
C	mutos	
D	mutos	TOIII 14.09.2015
E	mutos	TOIII 01.10.2015
F	mutos	

Suunn. Toim. /21.11.2013	Kokonaisuus	Sähköpiirros	Työnumero
Piirt. Toim.	Lehti	Piirustusnumero	
Tark.	3/7	S	ESVsm1011P115E

OHJAUSPIIRIKAAVIO
MAALÄMPÖPUMPPU

CONTROL CIRCUIT
GROUND HEAT PUMP

KOMPRESSORI 1
SÄHKYVASTUS LI
HEATER LI
IMMERSSION

HÄLYTYSKYTKENTÄ
ALARM CONNECTION

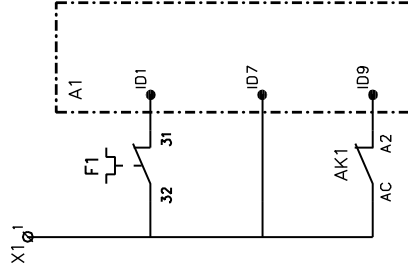

Kompressorin moottorisuoja F1
Compressor circle , Protection switch F1

Vaihevahti
Phase failure detector

KAIKKI 24V
JOHDOTUKSET
0,75MM2

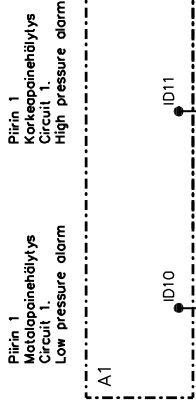

PS1 Pressostaatin toiminta
PS1 Pressostat activity
Paineeton Non-pressured, off
käynnillä Normal running, on
Matalapainehälytys Low pressure alarm, off

PS2 Pressostaatin toiminta
PS2 Pressostat activity
Paineeton Non-pressured, on
käynnillä Normal running, on
Korkeapainehälytys High pressure alarm, off

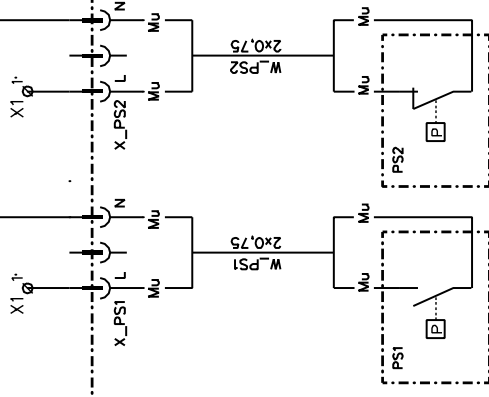

PS1 MATALAPAIN
PS2 KORKEAPAIN
PS1 LOW PRESSURE
PS2 HIGH PRESSURE

A	B	C
D muutos TOIII 14.09.2015	E muutos TOIII 01.10.2015	F muutos
A muutos TOIII 21.05.2015		
B muutos TOIII 3.08.2015		
C muutos TOIII 30.11.2015		

Suurm. TOIII 21.11.2013	Kokonaisuus	Sähköpostio	Työnumero
Piirt. TOIII	Lehti 4/7	Piirustusnumero	
Tark.	S Esvsm1011P115E		

OHJAUSPIIRIKAAVIO
MAALÄMPÖPUMPPU

CONTROL CIRCUIT
GROUND HEAT PUMP

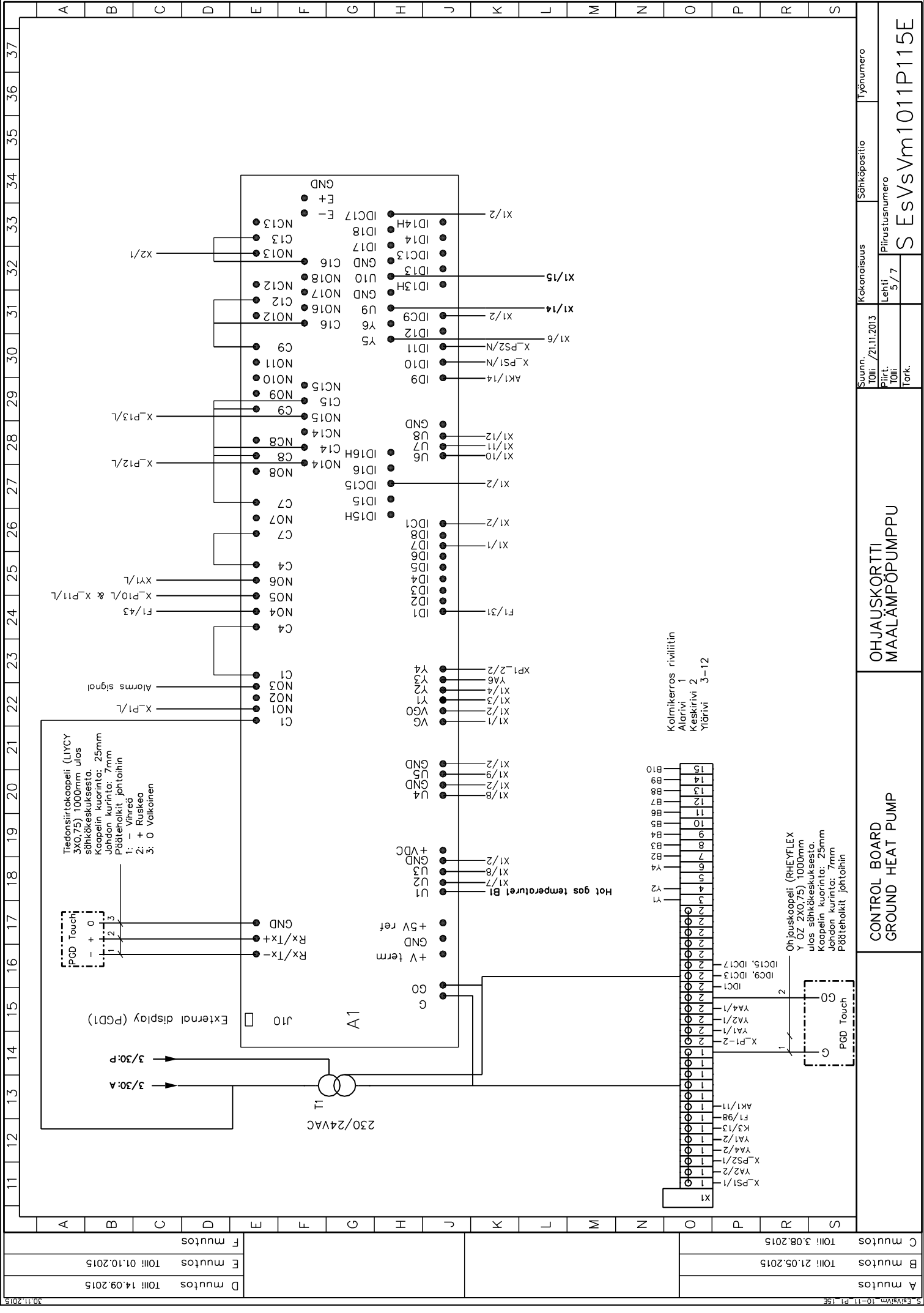

A	muitos	TOIII: 21.05.2015	
B	muitos	TOIII: 01.10.2015	
C	muitos	TOIII: 03.08.2015	

OHAUSKORTTI
MAALÄMPÖPUMPPU

CONTROL BOARD
GROUND HEAT PUMP

Suurin. Toili: /21.11.2013	Sähköposti	Työnnumero
Piirt. Toili: 5/7	Piirustusnumero	
Tark.		

S EsvsVm1011P115E

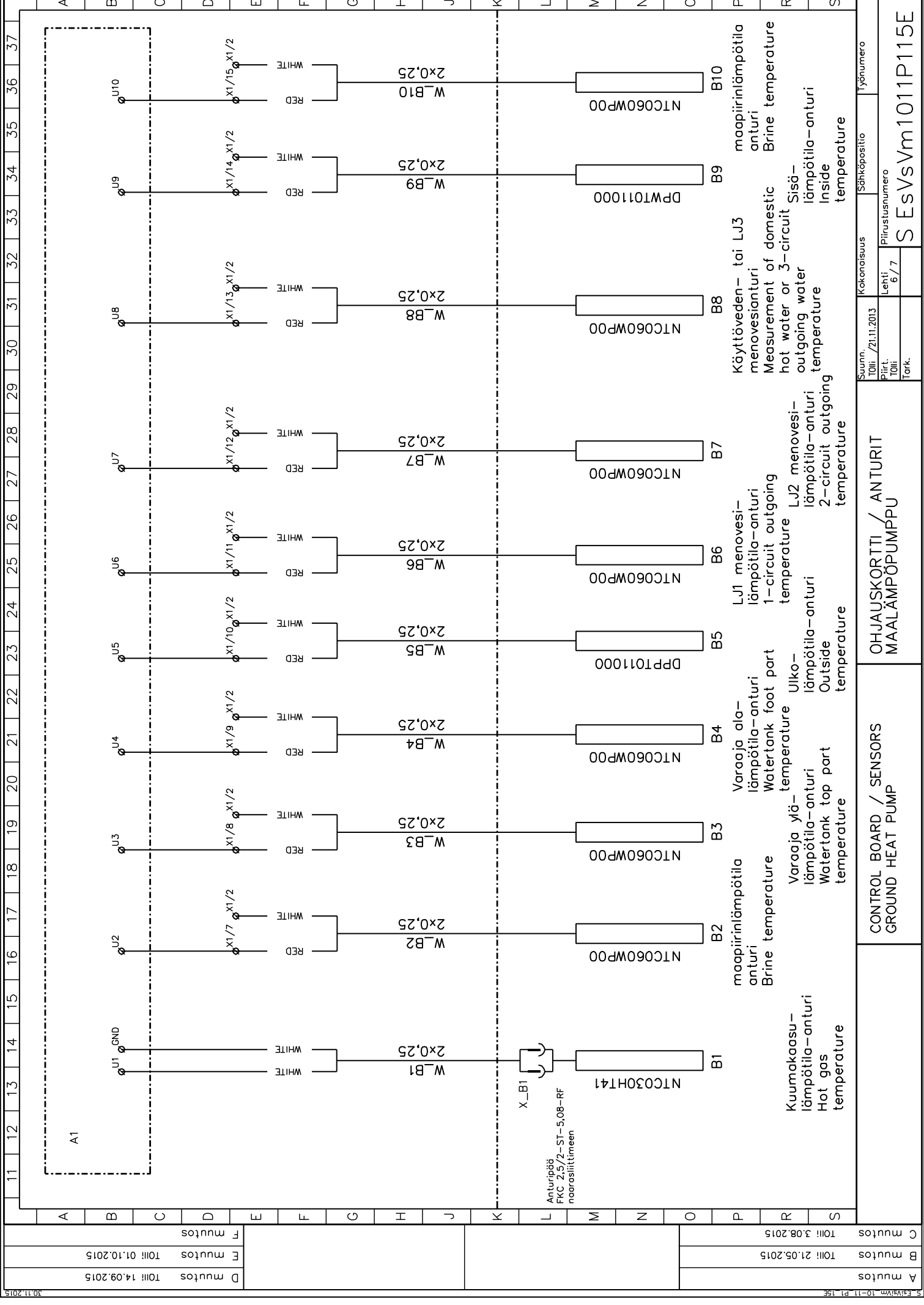

A	muutos	TOIII	21.05.2015
B	muutos	TOIII	01.10.2015
C	muutos	TOIII	03.08.2015

Suurin. Toili	/21.11.2013	Kokonaisuus	Sähköpiirros	Työnumero
Piirt. Toili		Lehti	Piirustusnumero	
Tark.		6/7		

OHJAUSKORTTI / ANTURIT
MAALÄMPÖPUMPPU

CONTROL BOARD / SENSORS
GROUND HEAT PUMP

S ESvsm1011P115E

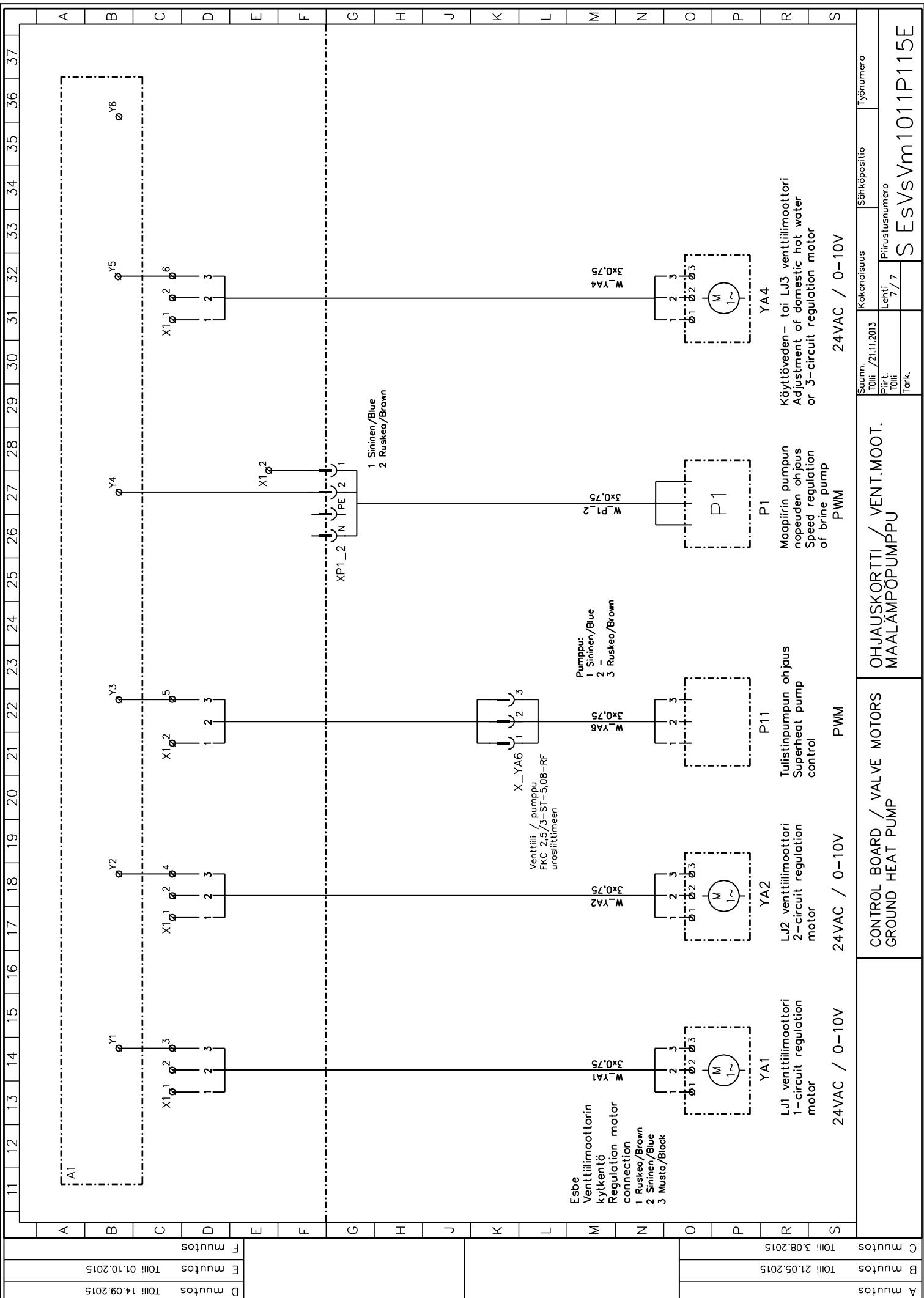

A	mutos	TOIII: 14.09.2015
B	mutos	TOIII: 21.05.2015
C	mutos	TOIII: 3.08.2015
D	mutos	TOIII: 01.10.2015
E	mutos	TOIII: 01.10.2015
F	mutos	

S	24VAC / 0-10V	24VAC / 0-10V	PWM	PWM	24VAC / 0-10V	24VAC / 0-10V
R	YA1 venttiilimoottori 1-circuit regulation motor	LJ2 venttiilimoottori 2-circuit regulation motor	Tulistinpumpun ohjaus Superheat pump control	Maapiirin pumpun nopeuden ohjaus Speed regulation of brine pump	Käyttöveden- tai LJ3 venttiilimoottori Adjustment of domestic hot water or 3-circuit regulation motor	Käyttöveden- tai LJ3 venttiilimoottori Adjustment of domestic hot water or 3-circuit regulation motor
P	YA2 venttiilimoottori 2-circuit regulation motor	YA4 venttiilimoottori 3-circuit regulation motor	P11 Tulistinpumpun ohjaus Superheat pump control	P1 Maapiirin pumpun nopeuden ohjaus Speed regulation of brine pump	P12 Maapiirin pumpun nopeuden ohjaus Speed regulation of brine pump	YA4 Käyttöveden- tai LJ3 venttiilimoottori Adjustment of domestic hot water or 3-circuit regulation motor
O	W1-YA1	W1-YA2	W1-YA6	W1-P1	W1-P12	W1-YA4
N	Esbe Venttiilimoottorin kytkentä Regulation motor connection	Venttiili / pumppu FKC 2,5/3-ST-5,08-RF urosliittimeen	X_YA6	Pumppu: 1 Sininen/Blue 2 Ruskeo/Brown 3 Musta/Black	XP1_2	W1-YA4
M	1 Ruskeo/Brown 2 Sininen/Blue 3 Musta/Black					
L						
K						
J						
H						
G						
F						
E						
D						
C						
B						
A						

OHJAUSAUTOMATIikka INTEGROITU LÄMPÖPUMPUUN
 (CONTROL SYSTEM IS INTEGRATED TO HEAT PUMP)
 P12 = Kiertovesipumppu lämmityspiiri 1
 TV01 = 4-tieventtiili lämmönjakopiiri 1

HUOM!
 Suosittelemme ÄSSÄSTREAM lisäosaa,
 jos kohteessa on käyttöveden kierto.
 ÄSSÄSTREAMIN lisääminen on erityisen
 tärkeää, jos kierolinjat on pitkä
 tai linjan häviöt ovat suuret

NOTE!
 ÄSSÄSTREAM recommended when
 heat losses of hot water
 circulation line is high

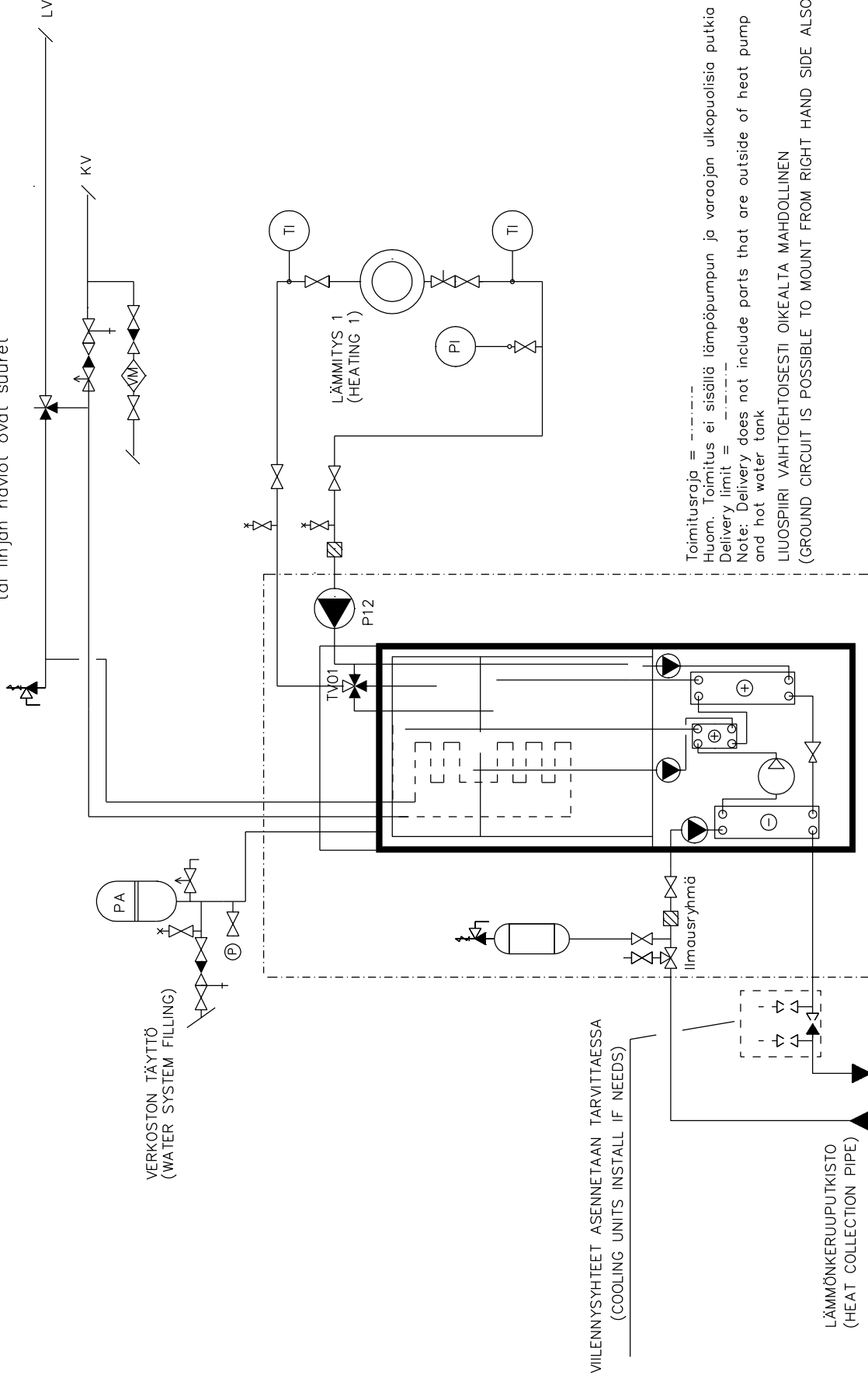

Toimitusraja = - - - - -
 Huom. Toimitus ei sisällä lämpöpumpun ja varaajan ulkopuolisia putkia tai niiden osia
 Delivery limit = - - - - -
 Note: Delivery does not include parts that are outside of heat pump
 and hot water tank
 LIUOSPIIRI VAIHTOEHTOISESTI OIKEALTA MAHDOLLISEN
 (GROUND CIRCUIT IS POSSIBLE TO MOUNT FROM RIGHT HAND SIDE ALSO)

SUUNNITTELUALA, TYÖN JA PIIRUSTUKSEN N:O	LVI KYTKENTÄKAAVIO/1-PIIRIKYTKENTÄ	
	L	Vsi614 1 13A
LEHTI	LEHDISTÄ	
	TILAAJAN N:O	
SUUNNITTELUALA, TYÖN JA PIIRUSTUKSEN N:O	LVI KYTKENTÄKAAVIO/1-PIIRIKYTKENTÄ	
	L	Vsi614 1 13A
LEHTI	LEHDISTÄ	
	TILAAJAN N:O	
SUUNNITTELUALA, TYÖN JA PIIRUSTUKSEN N:O	HVAC SCHEMATIC/1-CIRCUIT CONNECTIONS	
	L	Vsi614 1 13A
LEHTI	LEHDISTÄ	
	TILAAJAN N:O	
SUUNNITTELUALA, TYÖN JA PIIRUSTUKSEN N:O	LVI KYTKENTÄKAAVIO/1-PIIRIKYTKENTÄ	
	L	Vsi614 1 13A
LEHTI	LEHDISTÄ	
	TILAAJAN N:O	

LÄMPÖÄSSÄ

SUUNN. HSG
 PVM 29.04.2013
 ALLEKIRJOTUS

HVAC SCHEMATIC/1-CIRCUIT CONNECTIONS
 ÄSSÄCONTROL
 LÄMPÖÄSSÄ Vsi 6-14

LVI KYTKENTÄKAAVIO/1-PIIRIKYTKENTÄ
 ÄSSÄCONTROL
 LÄMPÖÄSSÄ Vsi 6-14

SUUNNITTELUALA, TYÖN JA PIIRUSTUKSEN N:O
 MUUTOS
 L Vsi614 1 13A
 LEHTI
 TILAAJAN N:O

TUNN.	
LUKUM.	
MUUTOS	
PÄIVÄYS	

OHJAUSAUTOMAATIikka INTEGROITU LÄMPÖPUMPPUUN
(CONTROL SYSTEM IS INTEGRATED TO HEAT PUMP)

- P12 = Kiertovesipumppu lämmityspiiri 1
- P13 = Kiertovesipumppu lämmityspiiri 2
- TV01 = 4-tieventtiili lämmönjakopiiri 1
- TV02 = 3-tieventtiili lämmönjakopiiri 2

HUOM!
Suosittelemme ÄSSÄSTREAM lisäosaa, jos kohteessa on käyttöveden kierto. ÄSSÄSTREAMIN lisääminen on erityisen tärkeää, jos kierolinjat on pitkä tai linjan häviöt ovat suuret

NOTE!
ÄSSÄSTREAM recommended when heat losses of hot water circulation line is high

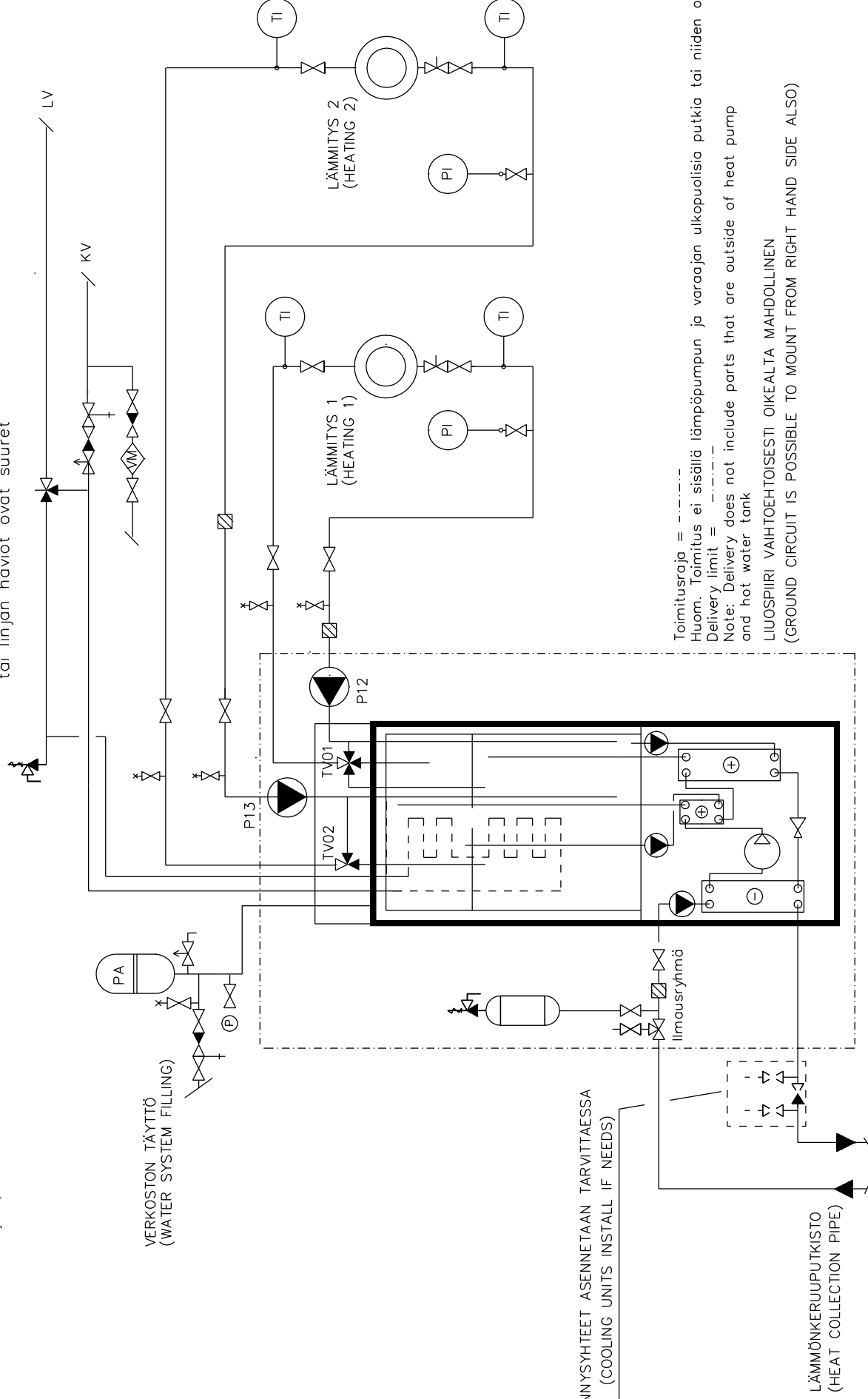

VERKOSTON TÄYTTÖ
(WATER SYSTEM FILLING)

VILENNYSYHTEET ASENNETAAN TARVITTAESSA
(COOLING UNITS INSTALL IF NEEDS)

LÄMMÖNKERUUPUTKISTO
(HEAT COLLECTION PIPE)

Toimitusryhmä =
Huom. Toimitus ei sisällä ulkopuolisia putkia tai niiden osia
Delivery limit =
Note: Delivery does not include parts that are outside of heat pump and hot water tank

LIUOSPIIRI VAIHTOEHTOISESTI OIKEALTA MAHDOLLISEN
(GROUND CIRCUIT IS POSSIBLE TO MOUNT FROM RIGHT HAND SIDE ALSO)

LÄMPÖÄSSÄ

HVAC SCHEMATIC/2-CIRCUIT CONNECTIONS
ÄSSÄCONTROL
LÄMPÖÄSSÄ Vs 6-14

LVI KYTKENTÄKAAVIO/2-PIIRIKYTKENTÄ
ÄSSÄCONTROL
LÄMPÖÄSSÄ Vs 6-14

SUUNNITTELUALA, TYÖN JA PIIRUSTUKSEN N:O
L Vs614 2 13A
LEHTI LEHDISTÄ TILAAJAN N:O

TUNN. LUKUM. MUUTOS

PÄIVÄYS NIM.

Lämpöässä is a trademark of Suomen Lämpöpumpputekniikka Oy. We reserve the right to make changes.

Suomen Lämpöpumpputekniikka Oy

Unikontie 2

62100 Lapua

FINLAND

www.lampoassa.com

